

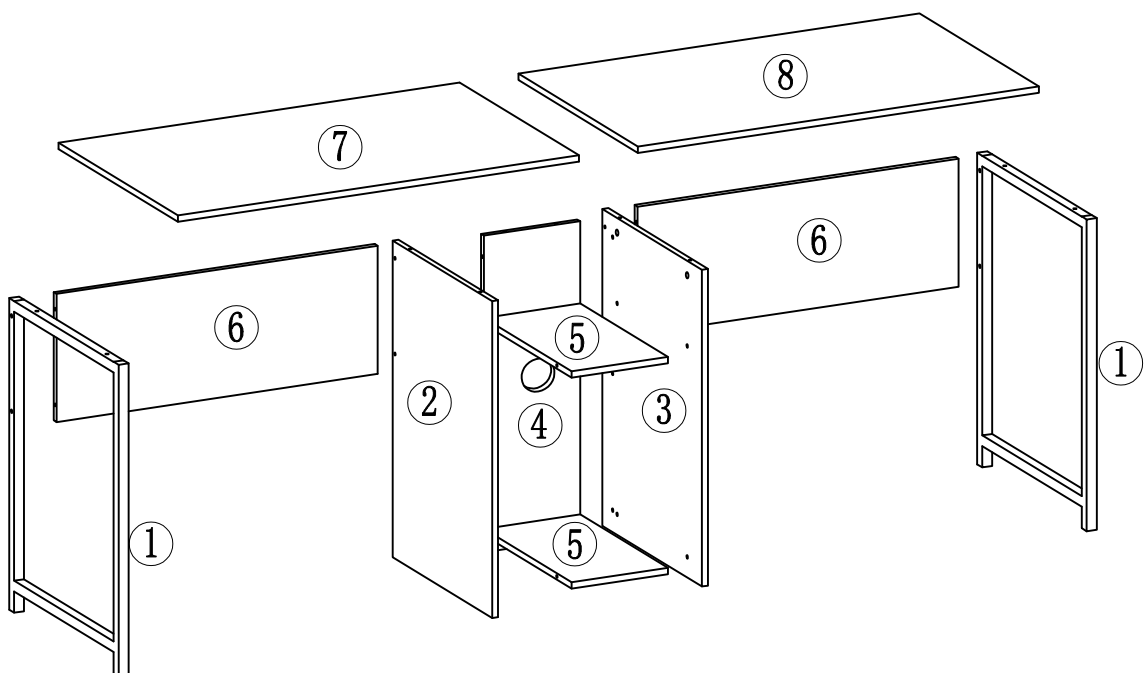

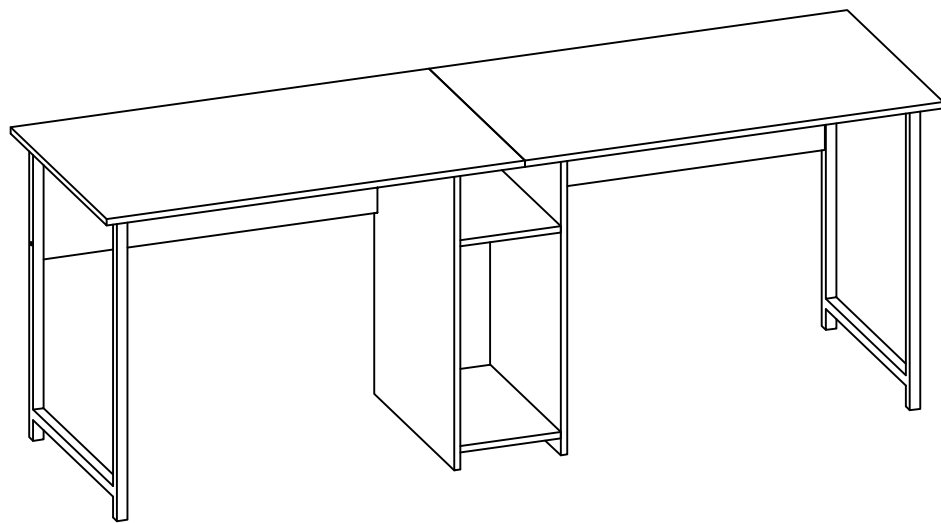



# ASSEMBLY INSTRUCTIONS



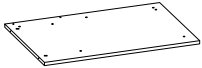
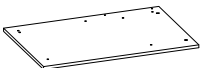
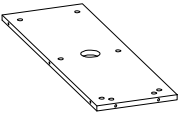
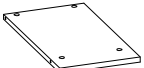





SKU: WF198327AAK

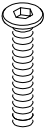

## Part List

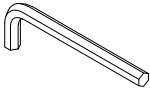
				
① x2Pcs	② x1Pc	③ x1Pc	④ x1Pc	⑤ x2Pcs
				
⑥ x2Pcs	⑦ x1Pc	⑧ x1Pc		

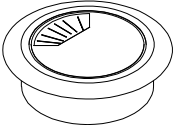
## Hardware List

				
Ax20Pcs	Bx20Pcs	M6x50 Cx8Pcs	M6x35 Dx4Pcs	Ex8Pcs
				
Fx1Pc	Gx4Pcs	Hx1Pc	Kx1Pc	

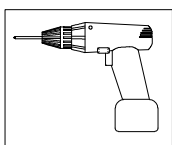

PLEASE BE CAREFUL DO NOT DAMAGE THE HOLE POSITION WHEN YOU USE POWER TOOLS !

# Step 1

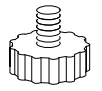

Gx4Pcs

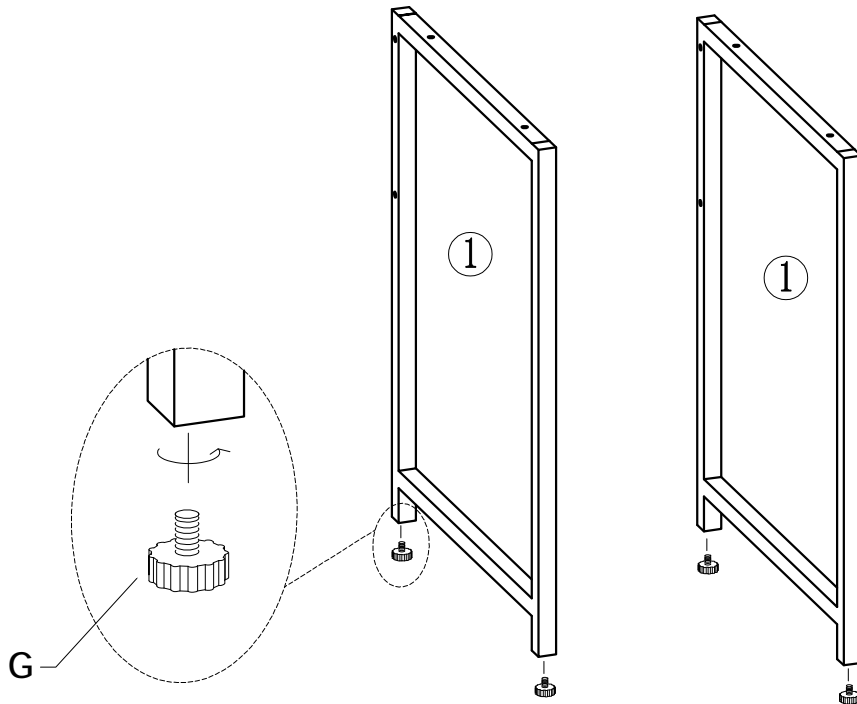

# Step 2



Kx1Pc



Ax14Pcs

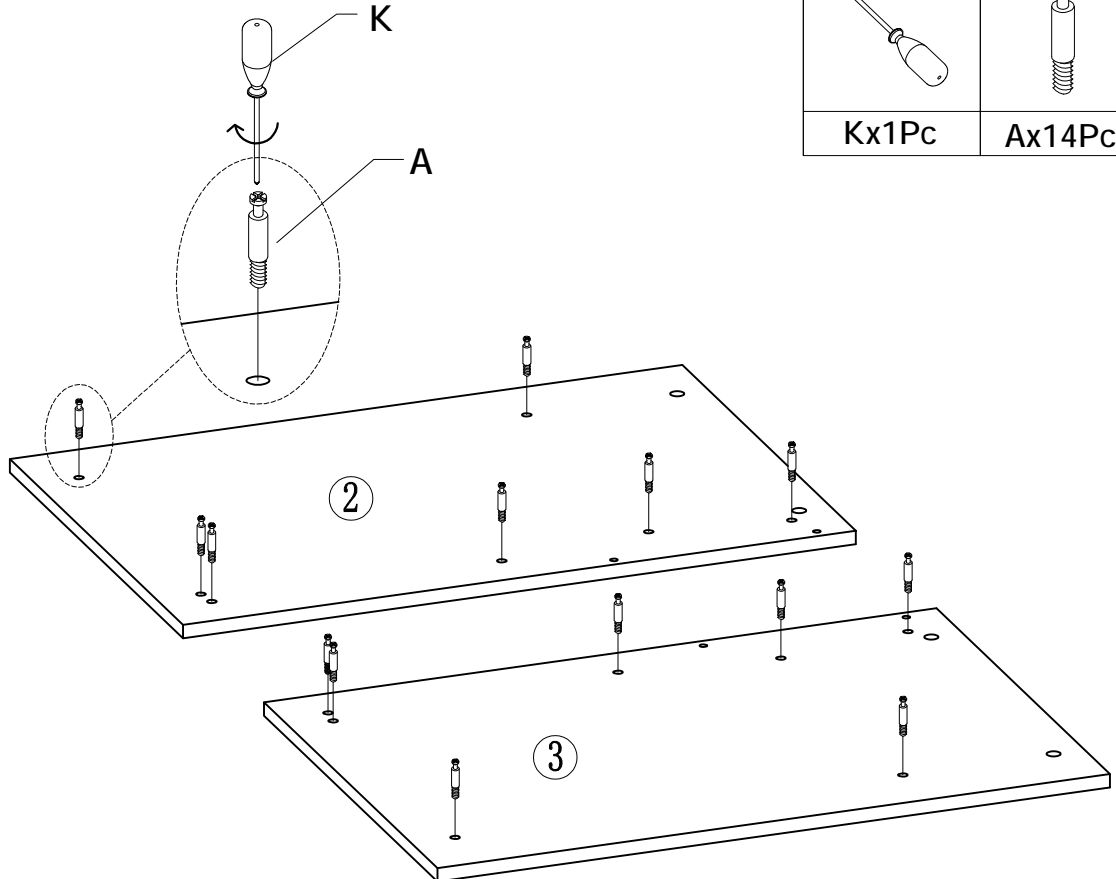

# Step 3

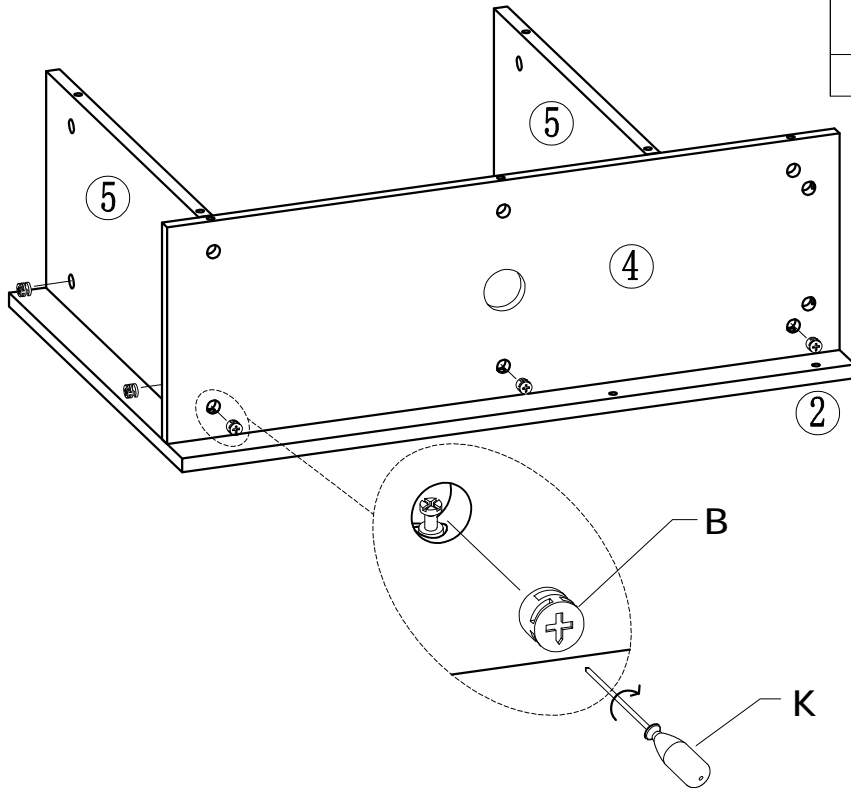

Kx1Pc



Bx7Pcs

# Step 4

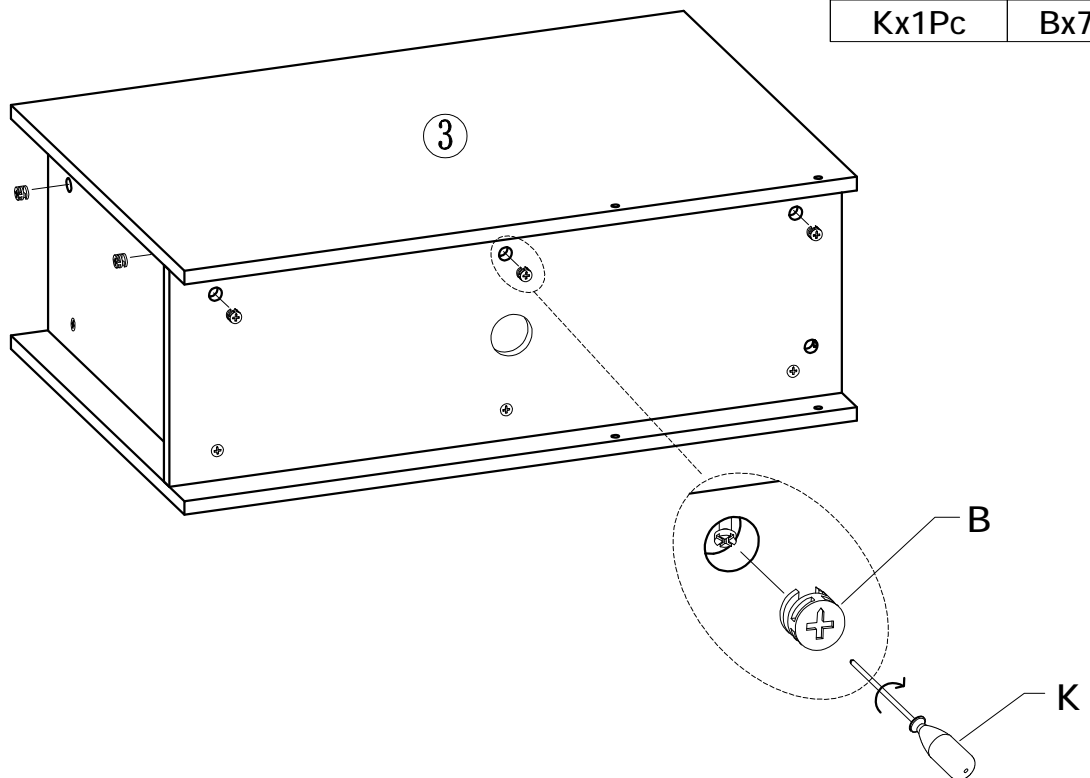

Kx1Pc



Bx7Pcs

# Step 5



Ex8Pcs

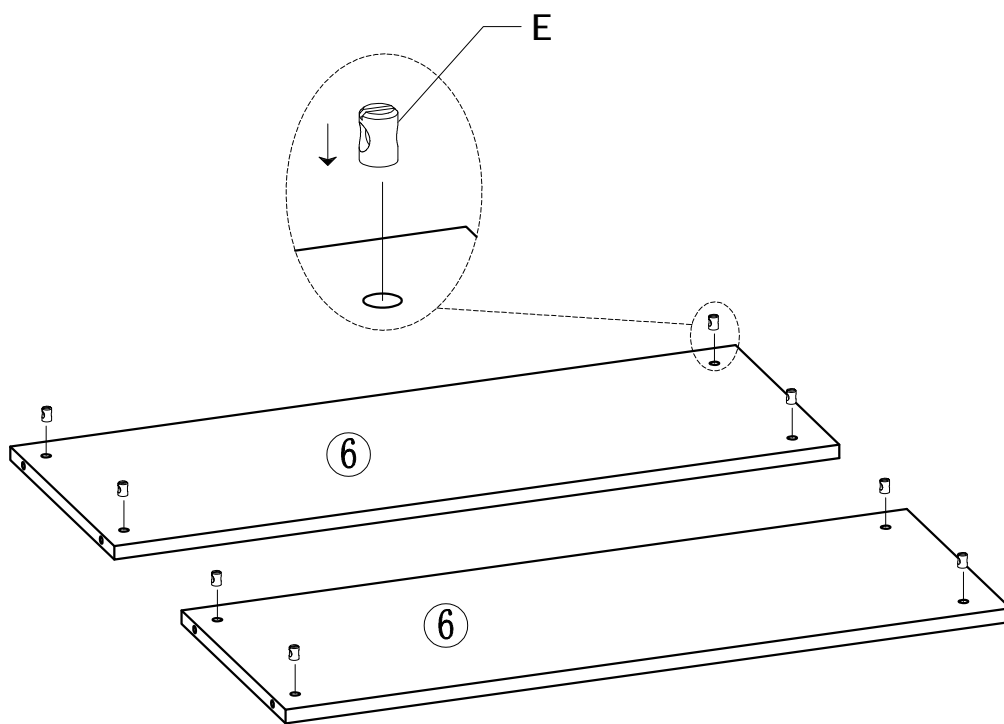

# Step 6

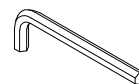

Fx1Pc



M6x50  
Cx8Pcs

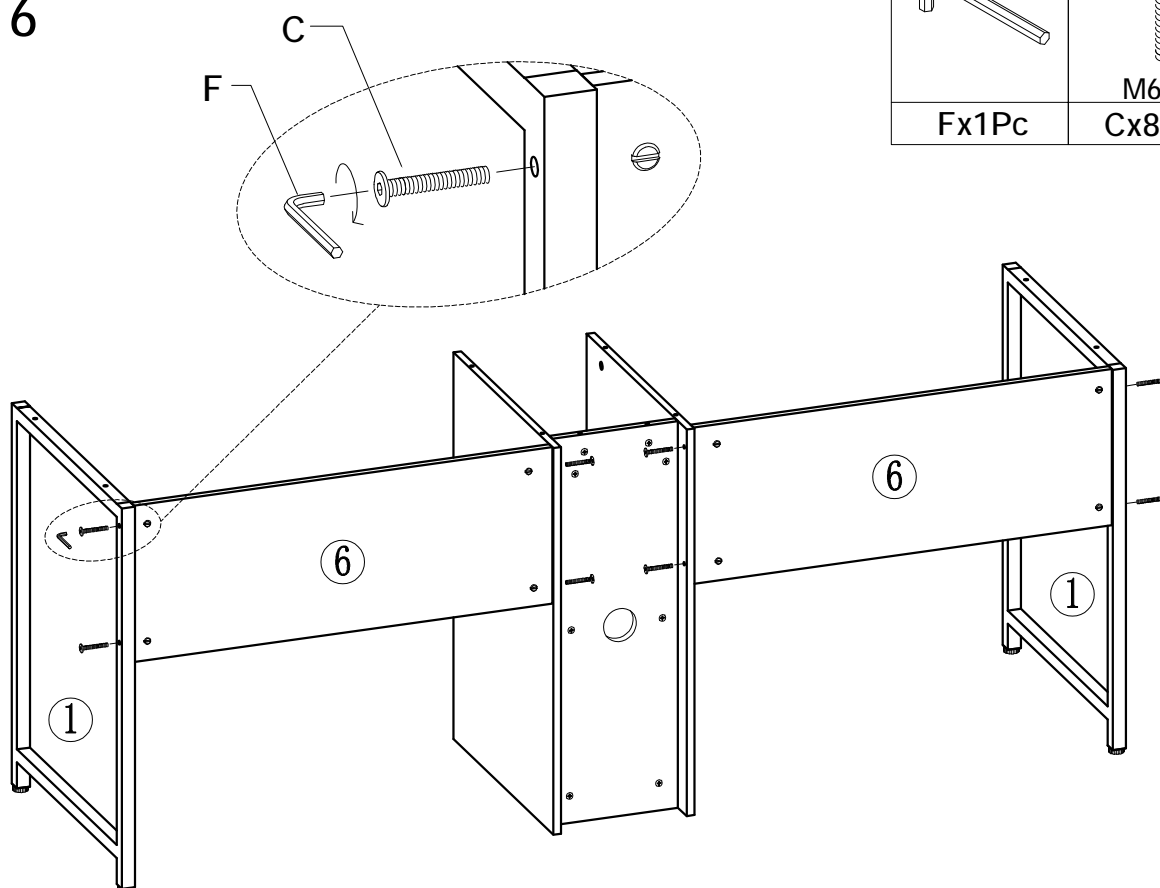

# Step 7

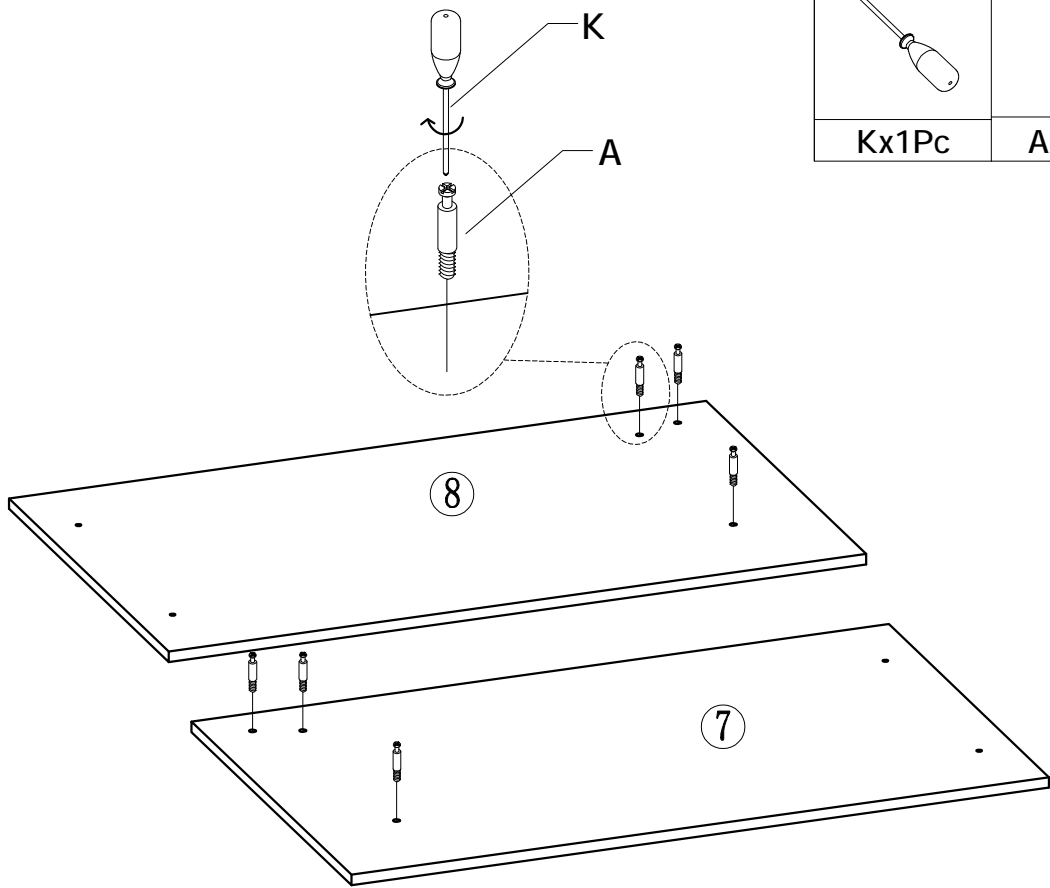

# Step 8

