

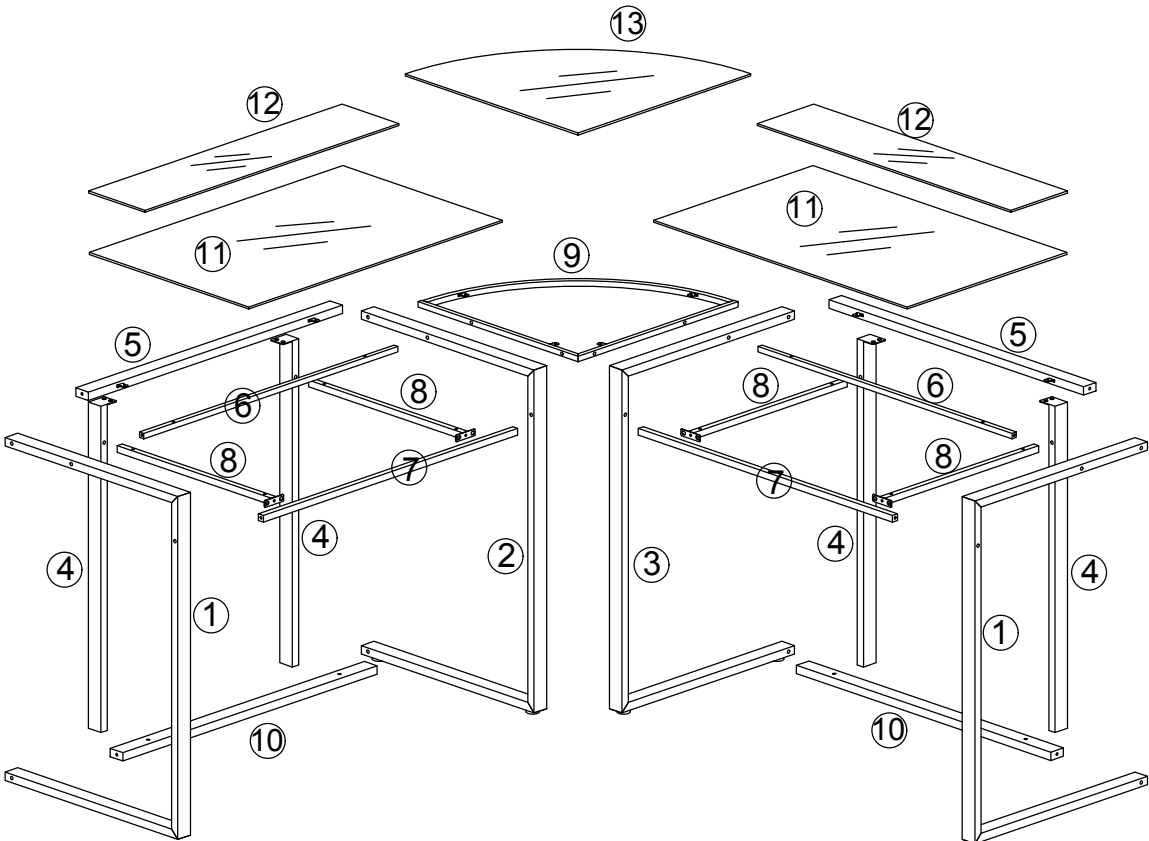

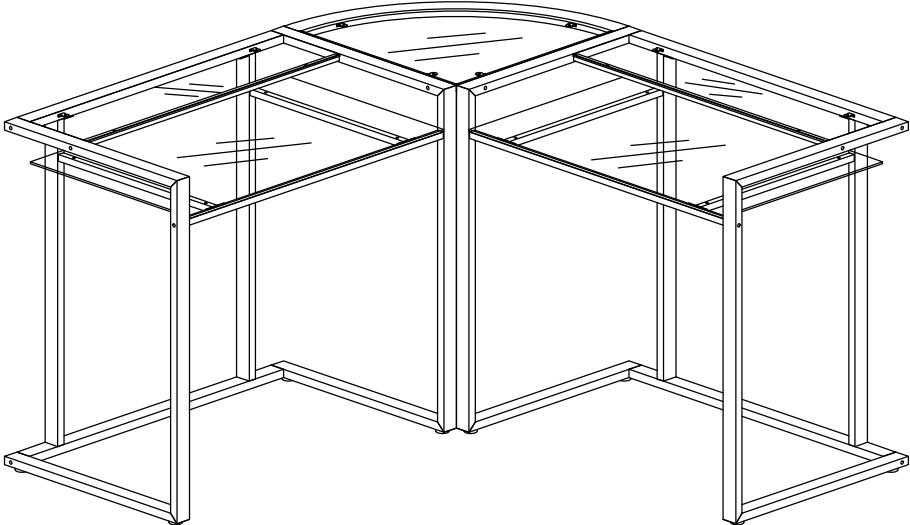





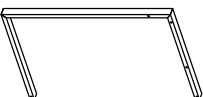
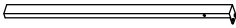

ASSEMBLY INSTRUCTIONS





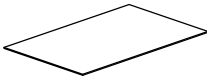



SKU: WF195579AAD

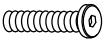

Part List

			
①×2pcs	②×1pc	③×1pc	④×4pcs
			
⑤×2pcs	⑥×2pcs	⑦×2pcs	⑧×4pcs
			
⑨×1pc	⑩×2pcs	⑪×2pcs	⑫×2pcs
			
⑬×1pc			

Hardware List

			
M6×12mm A×16pcs	M6×22mm B×2pcs	M6×40mm C×4pcs	M6×60mm D×18pcs
			
M6×75mm E×2pcs	F×20pcs	G×8pcs	M4 H×1pc

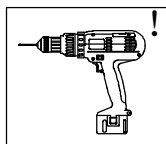

PLEASE BE CAREFUL DO NOT DAMAGE THE HOLE POSITION WHEN YOU USE POWER TOOLS !

Step 1

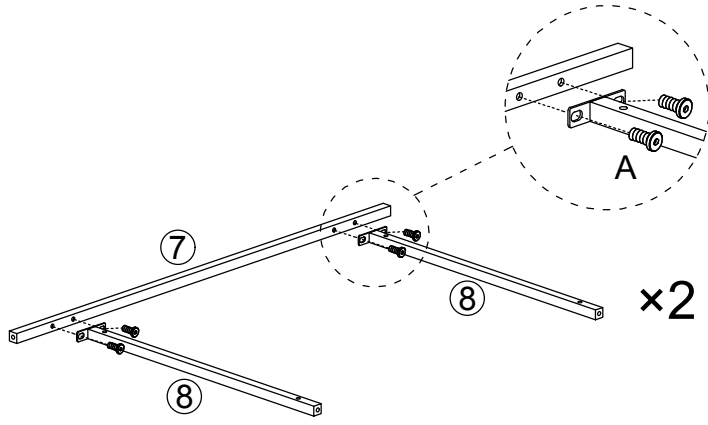

M6×12mm
A×8PCS

Step 2

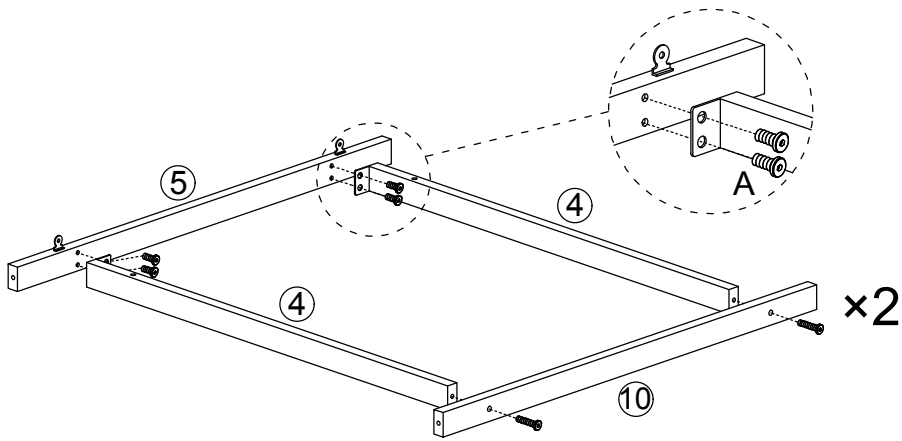

M6×12mm
A×8PCS

M6×40mm
C×4PCS

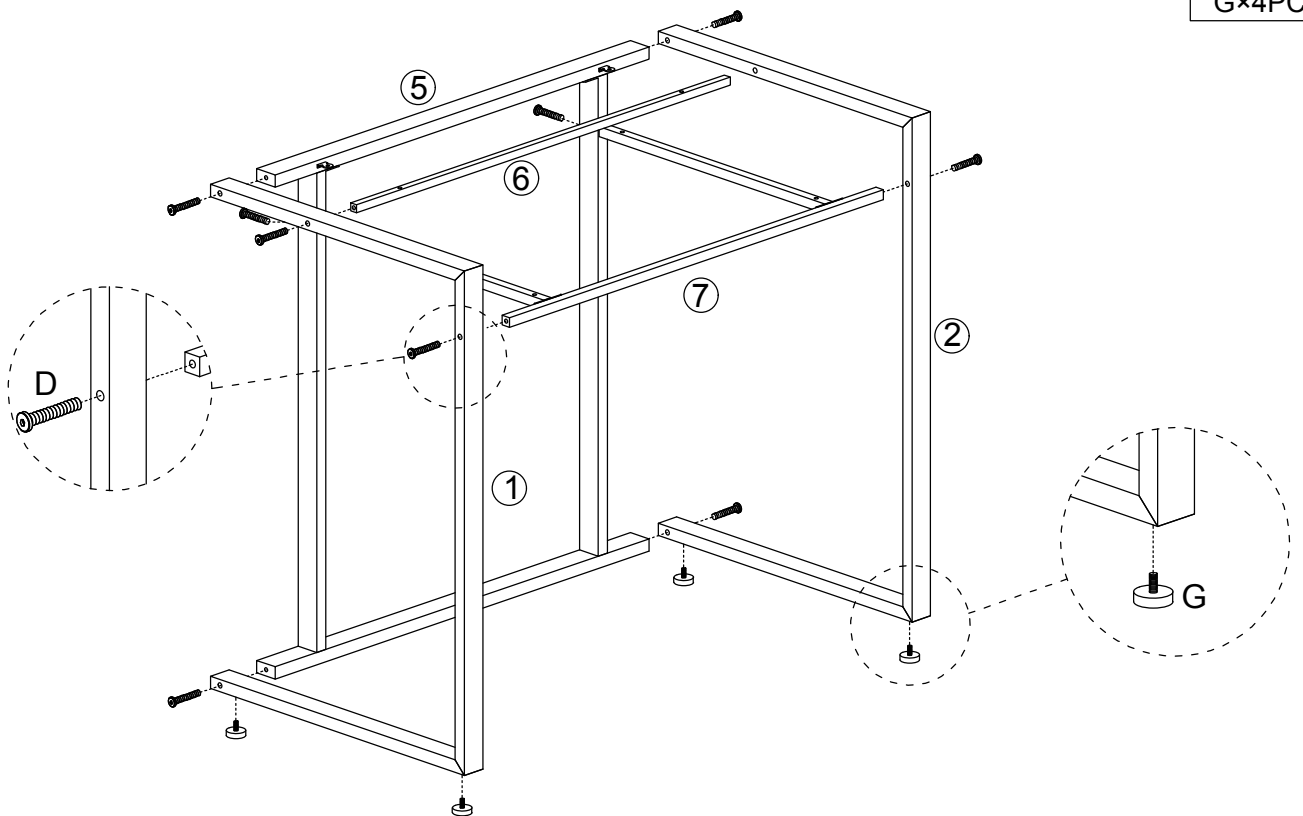

Step 3





M6×60mm
D×9PCS

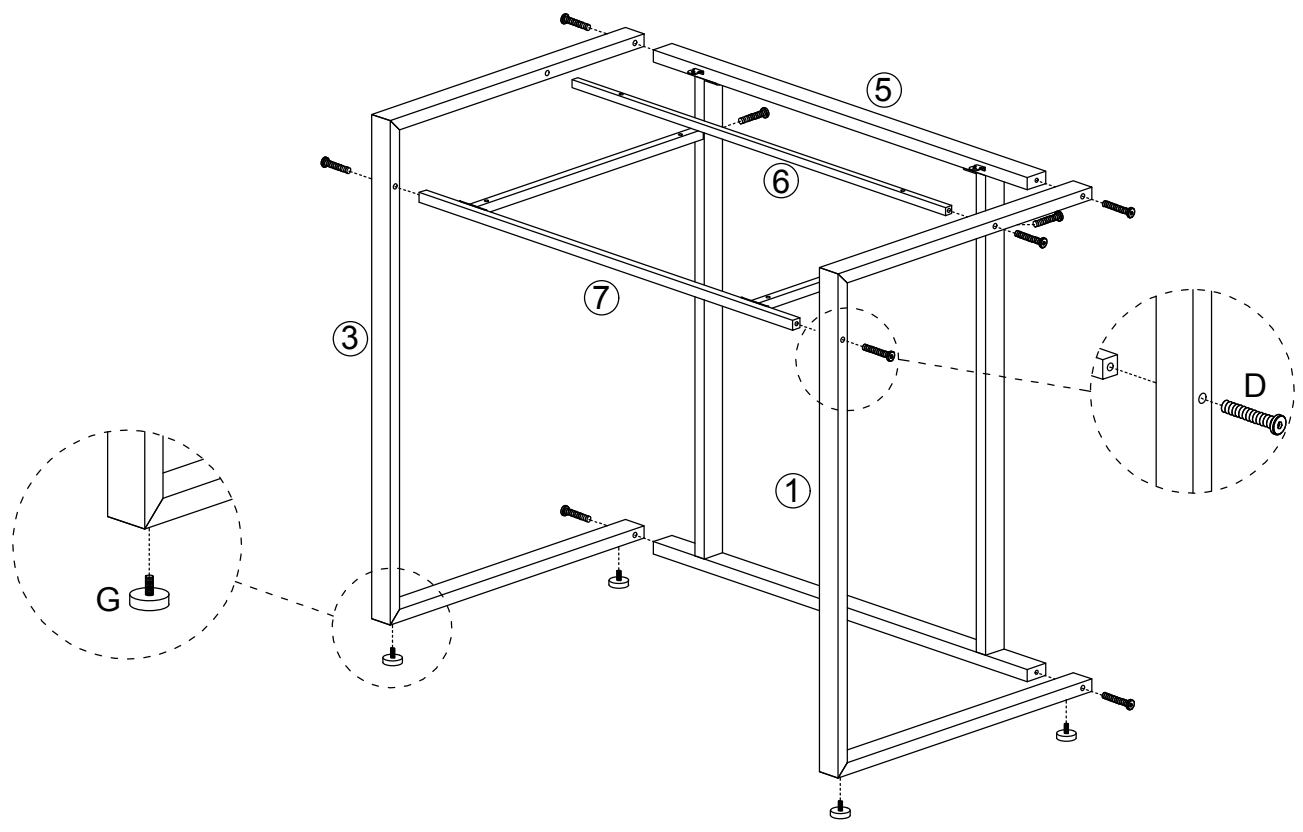

G×4PCS

Step 4

-  M6×60mm
D×9PCS
-  G×4PCS



Step 5

-  M6×22mm
B×2PCS
-  M6×75mm
E×2PCS

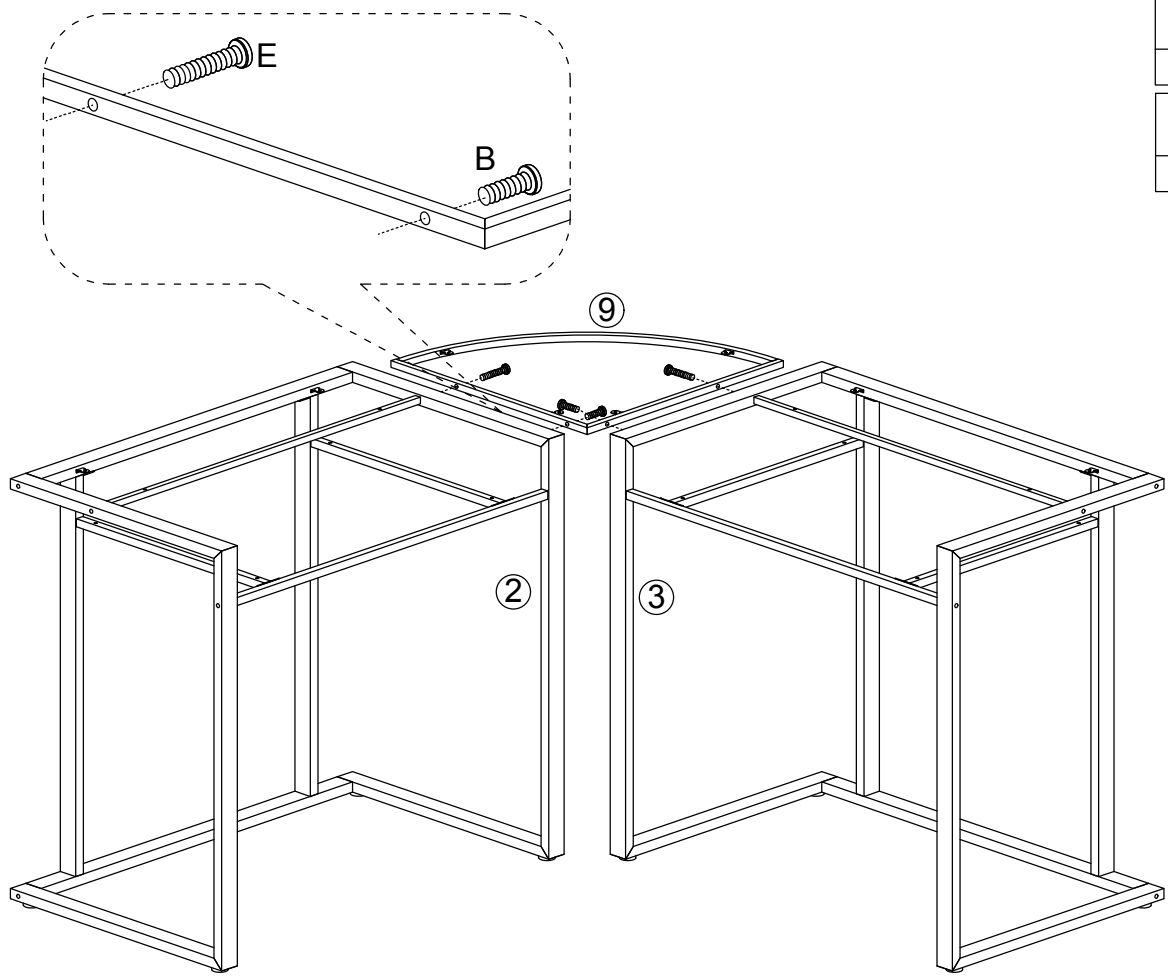

Step 6

F×20PCS

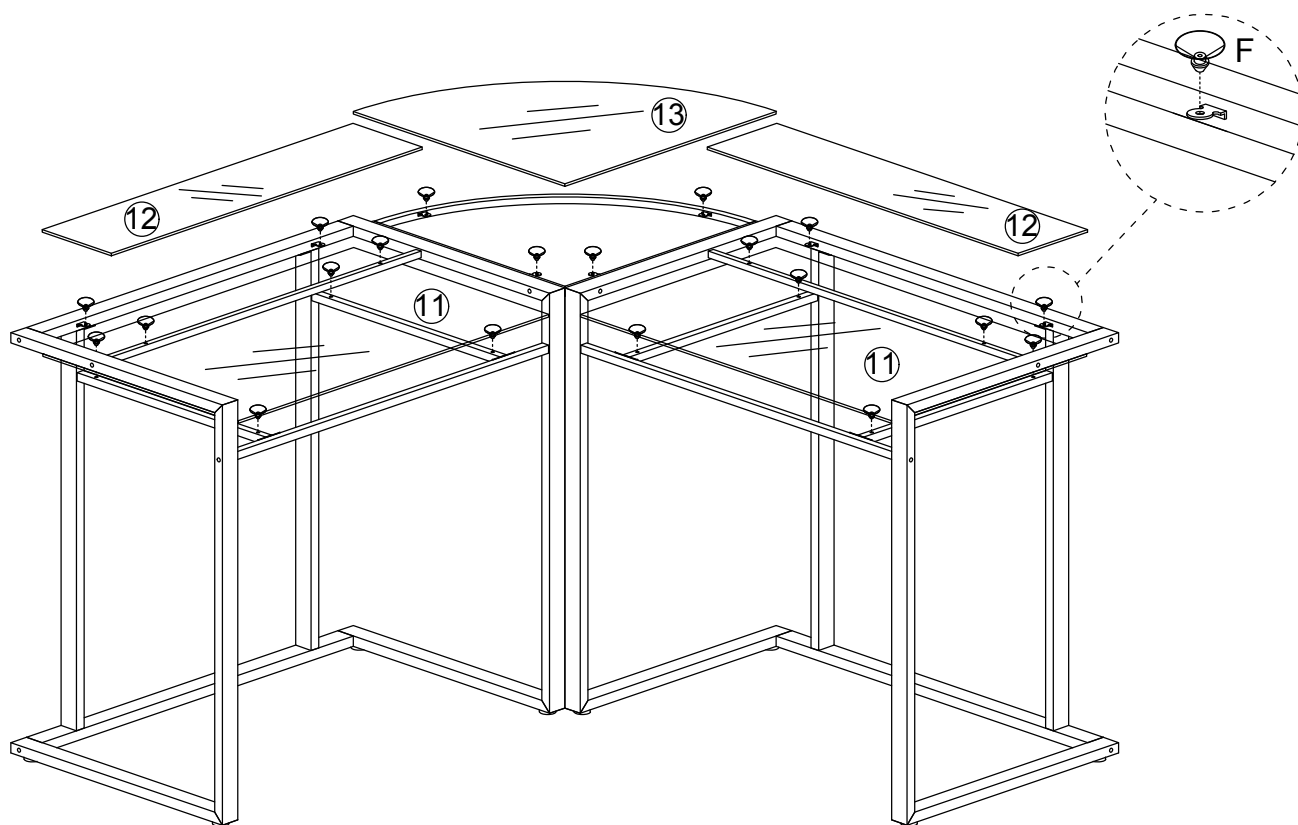

Step 7

