

# ASSEMBLY INSTRUCTION

---

## CORNER SOFA SET

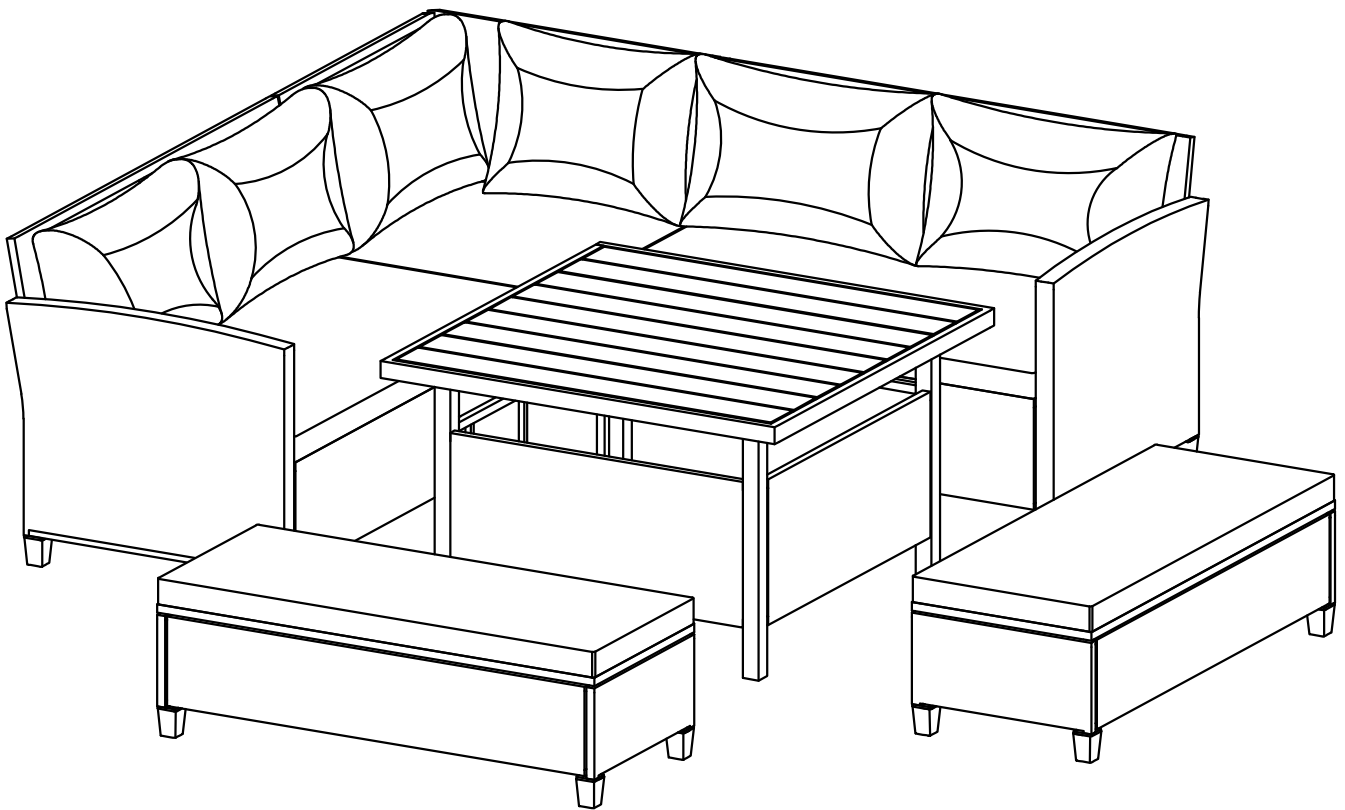

WF191811

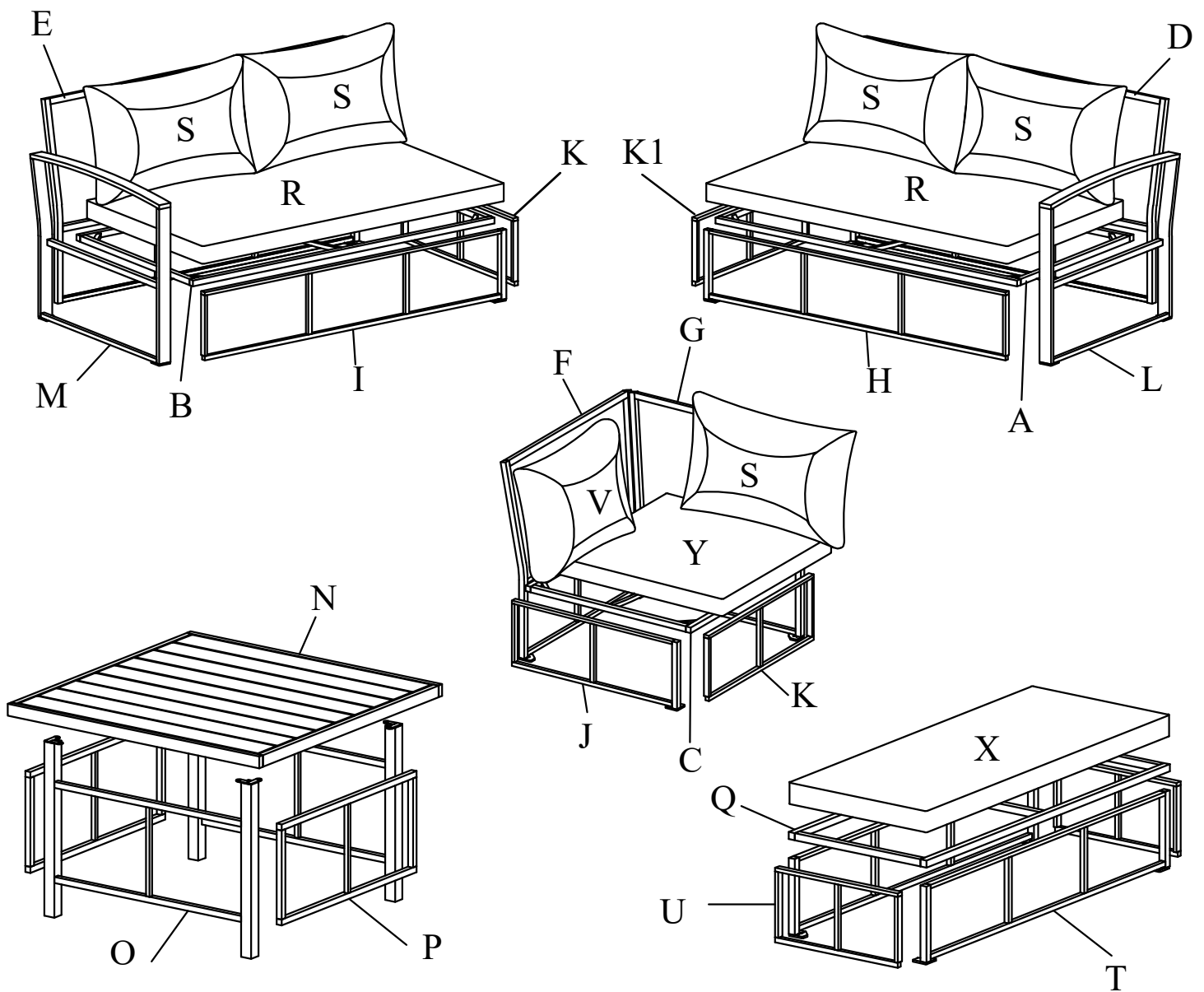

**Notice:**

1. 50% Tighten before fixing all screws, Allen wrench is recommended instead of an electric drill.
2. Place the item on a flat ground to adjust and make sure it remains stable.
3. Tighten up all screws with tools gradually.
4. If the screws are not aligned with holes during assembly, please loosen all the other screws to 50% and continue the assembly process.
5. If the item is not stable, please loosen all the screws, adjust it on a flat ground and tighten up all screws again.
6. Note : If one or some screws are fully tightened during assembly, chances are the others will not be aligned with holes. In addition, all the holes are designed to be relatively larger to provide more space for the adjustment of the screws.

# Part List

A

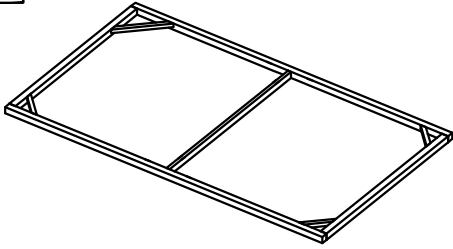

Bench Left Seat Frame (1pc)

B

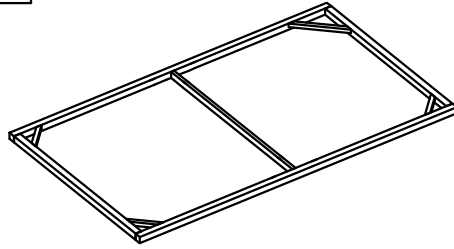

Bench Right Seat Frame (1pc)

C

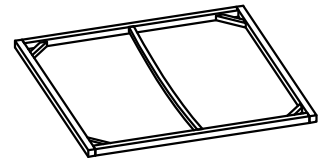

Corner Seat Frame (1pc)

D

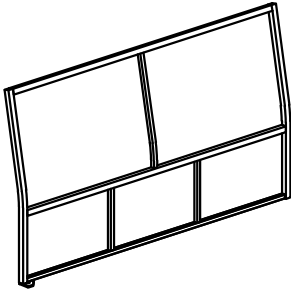

Bench Left Back Frame (1pc)

E

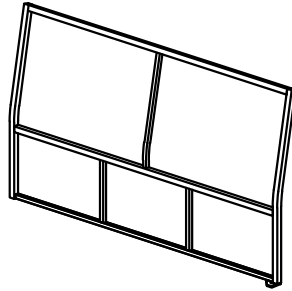

Bench Right Back Frame (1pc)

F

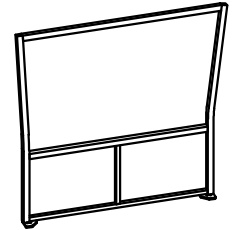

Corner Long Back Frame (1pc)

G

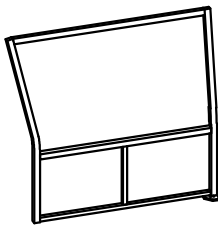

Corner Short Back Frame (1pc)

H

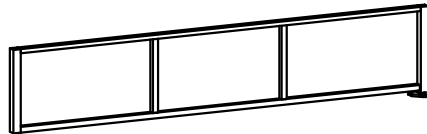

Bench Left Front Frame (1pc)

I

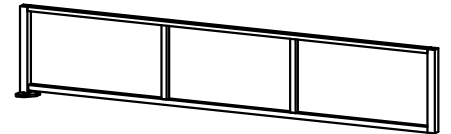

Bench Right Front Frame (1pc)

J

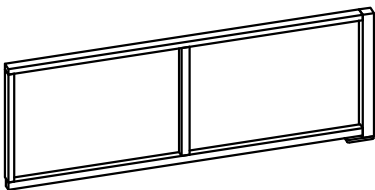

Corner Front Frame (1pc)

K

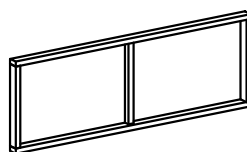

Bench/Corner Side Frame  
(3pcs)

L

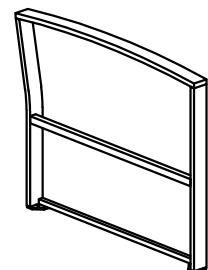

Bench Left Frame (1pc)

M

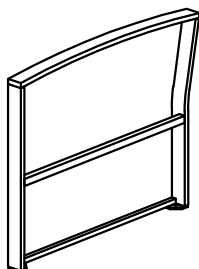

Bench Right Frame (1pc)

N

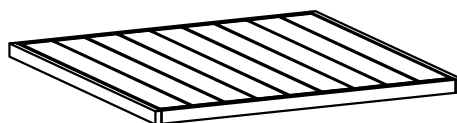

Table Top Frame (1pc)

O

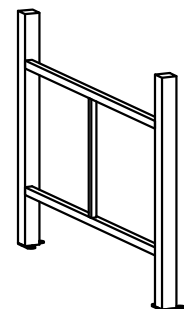

Table Leg Frame (2pcs)

# Part List

P

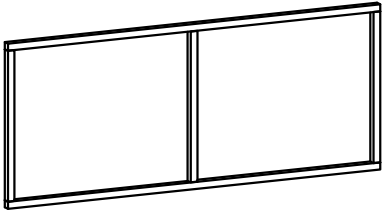
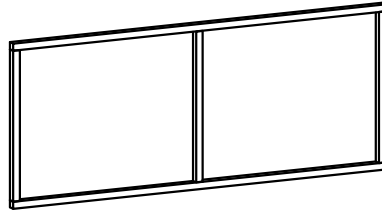

Table Side Fame (2pcs)

Q



Stool Top Frame (2pcs)

T

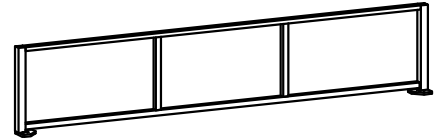

Stool Front Frame (2pcs)

U

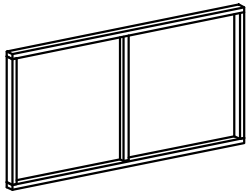

Stool Side Frame (2pcs)

R

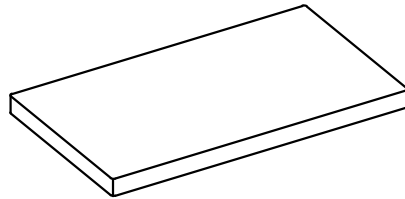

Bench Seat Cushion (2pcs)

S

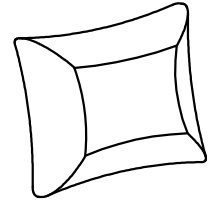

Back Long Cushion (5pcs)

V

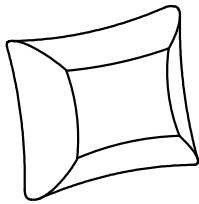

Back Short Cushion (1pc)

X

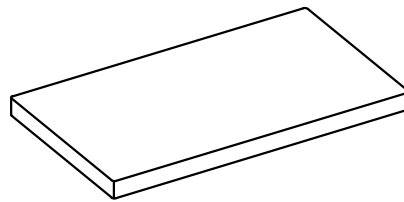

Stool Seat Cushion (2pcs)

Y

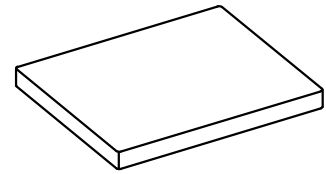

Corner Seat Cushion (1pc)

1

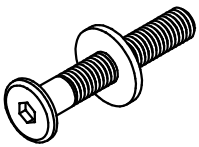

Bolt M6 x 15 mm  
(8 pcs)

2

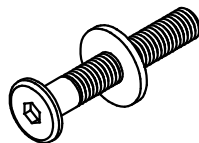

Bolt M6 x 30 mm  
(53 pcs)

3

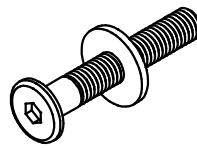

Bolt M6 x 40 mm  
(27 pcs)

4

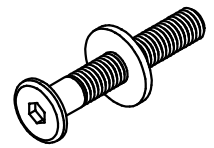

Bolt M6 x 45 mm  
(1 pc)

5

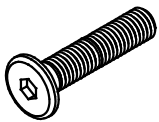

Bolt M6 x 55 mm  
(20 pcs)

6

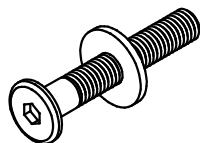

Bolt M6 x 60 mm  
(2 pcs)

7

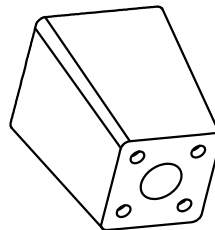

Plastic Feet (20 pcs)

8

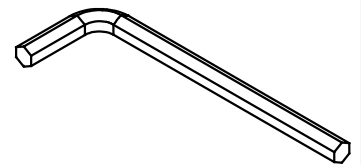

Allen Key M4 (1pc)

### STEP 1 (Bench Left Assembly)

Connect Bench Left Seat Frame (A) & Bench Left Back Frame (D) with Bolt (3)

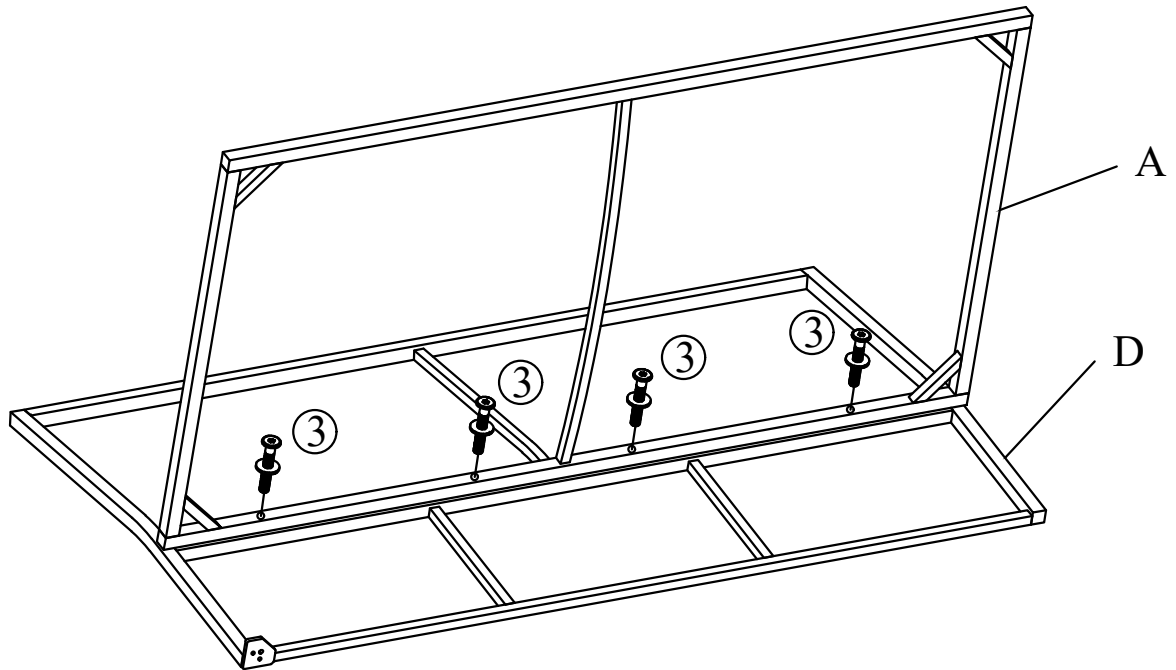

### STEP 2

Connect part from STEP 1 & Bench Left Frame (L) with Bolt (3), (6)

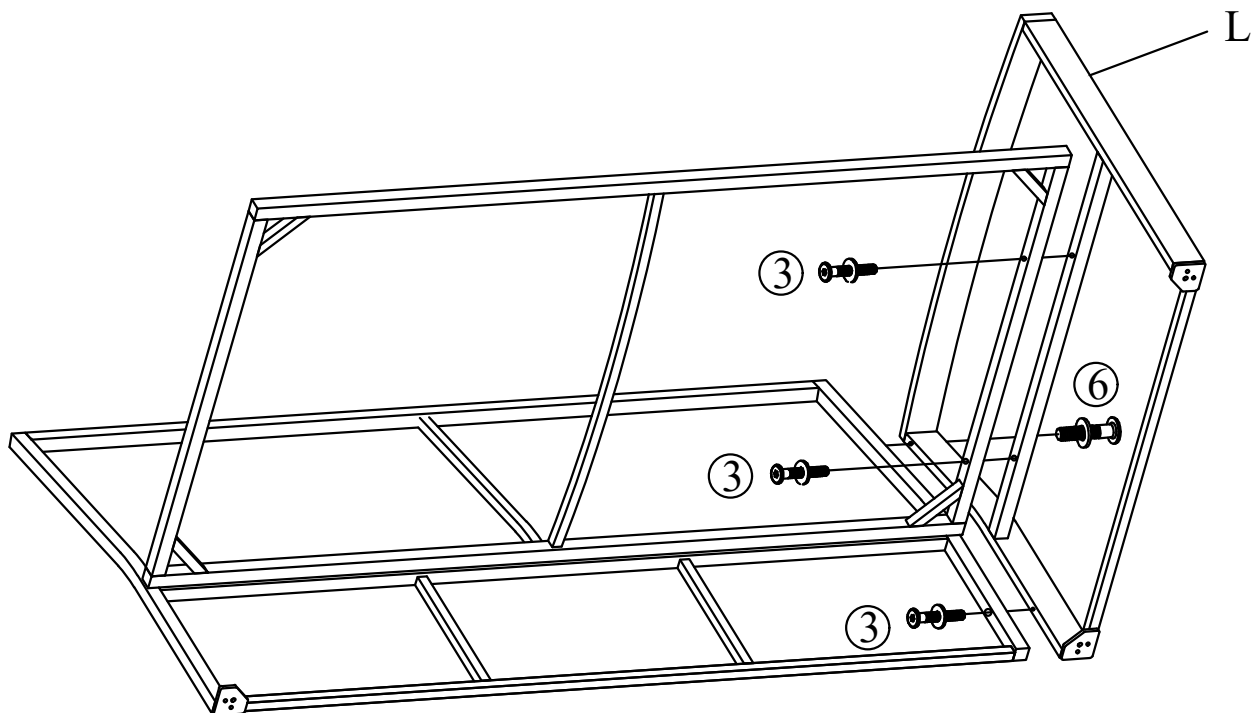

### STEP 3

Connect part from STEP 2 & Bench Left Side Frame (K1) with Bolt (2)

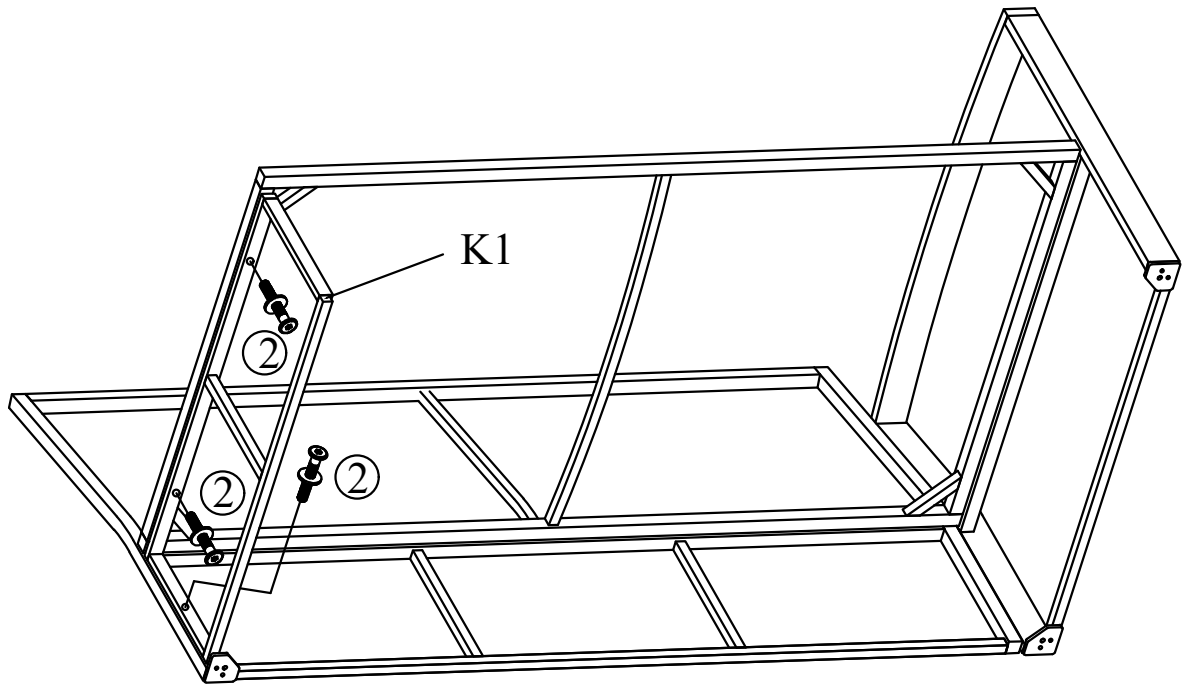

### STEP 4

Connect part from STEP 3 & Bench Left Front Frame (H) with Bolt (2)

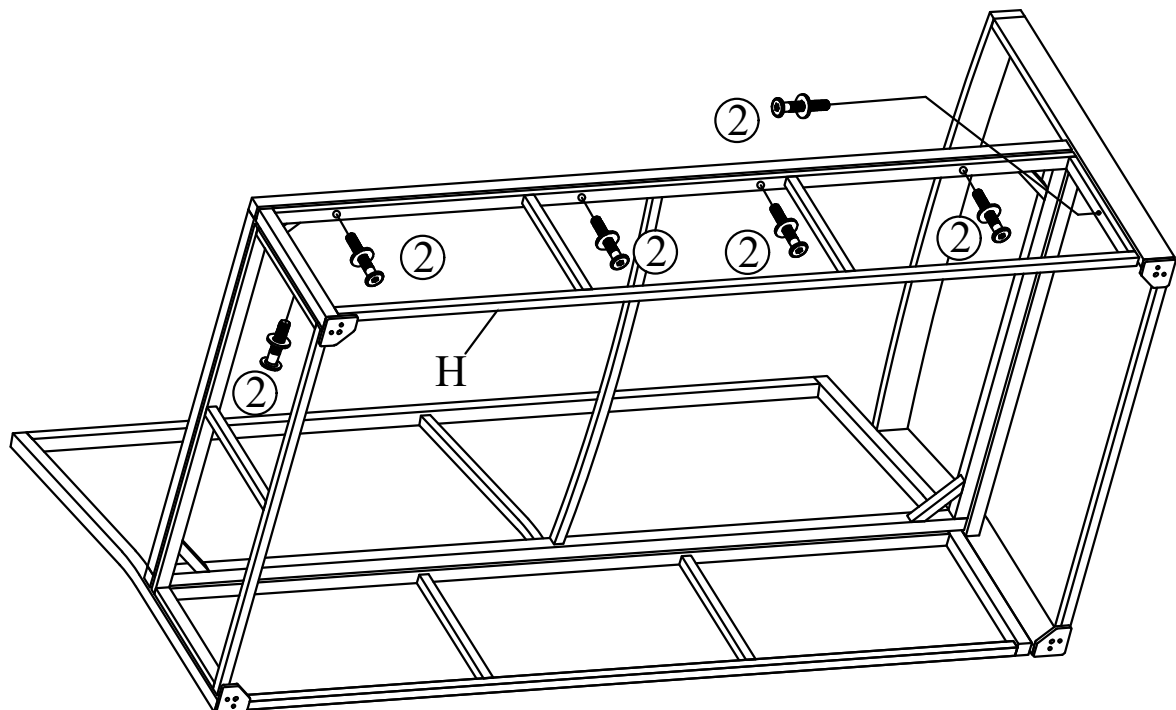

## STEP 5

Connect part from STEP 4 & Plastic Feet (7) with Bolt (5)

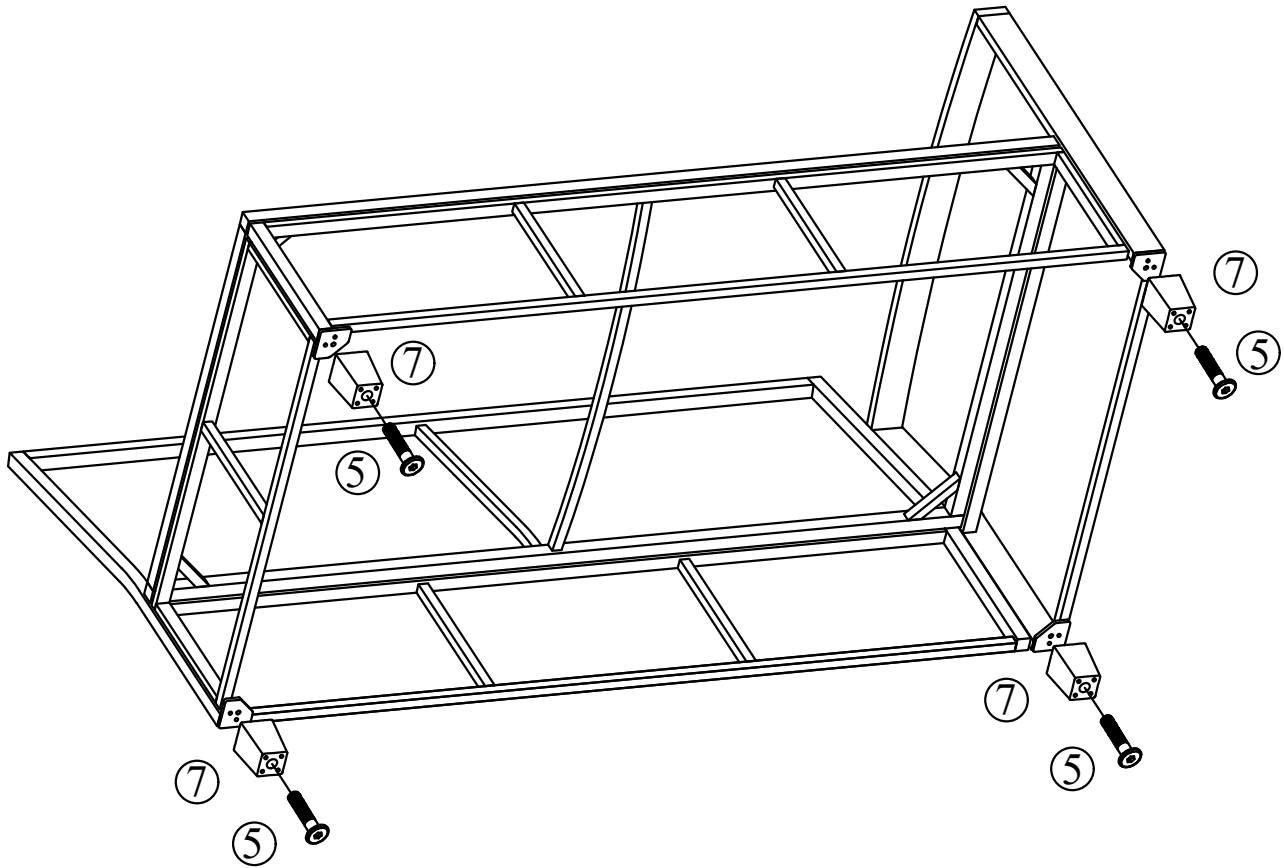

## STEP 6

Put on Bench Cushion (R), Back Long Cushion (S) to complete Bench

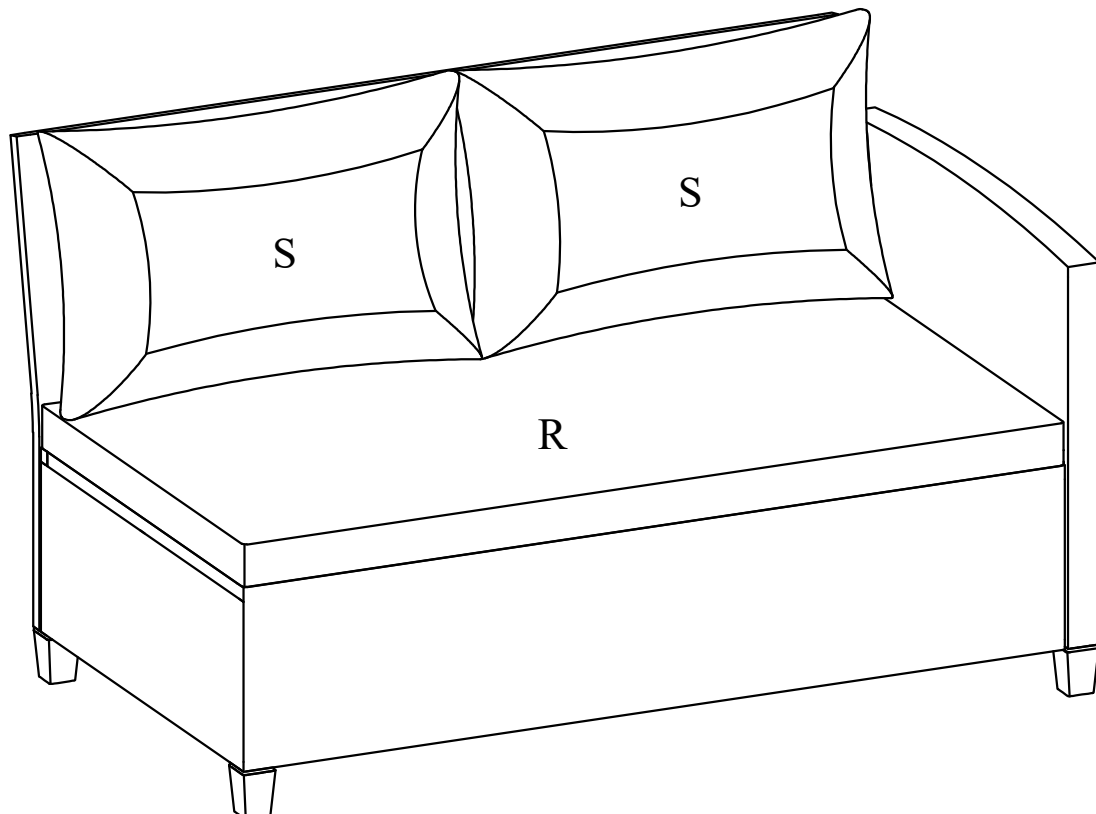

### STEP 7 (Bench Right Assembly)

Connect Bench Right Seat Frame (B) & Bench Left Back Frame (E) with Bolt (3)

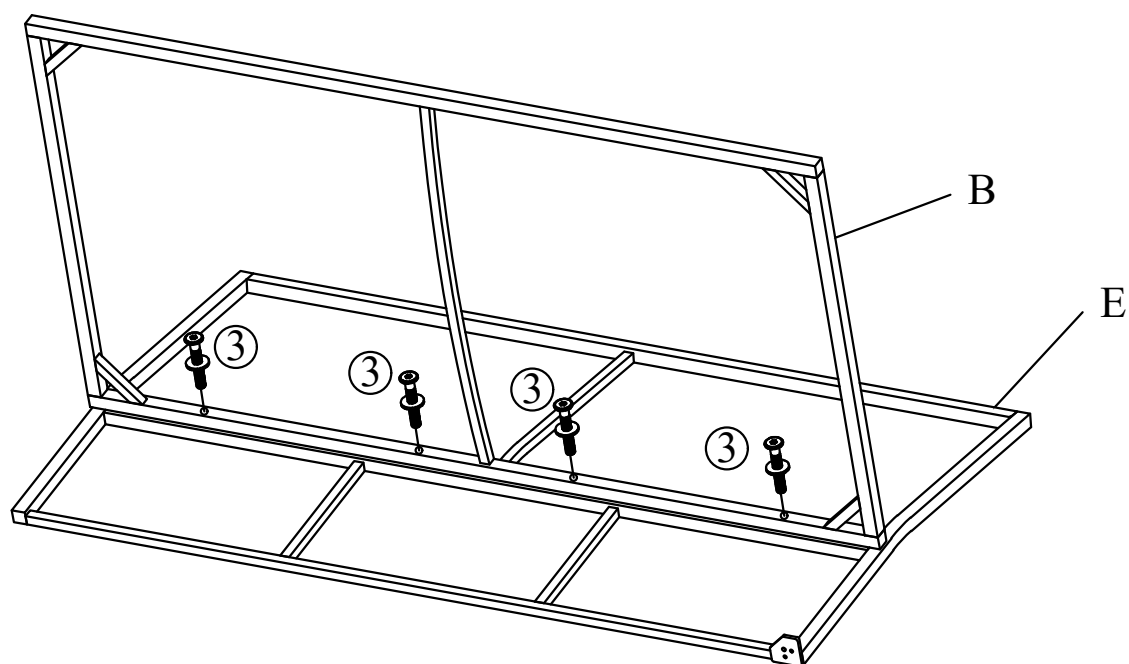

### STEP 8

Connect part from STEP 7 & Bench Right Frame (M) with Bolt (3), (6)

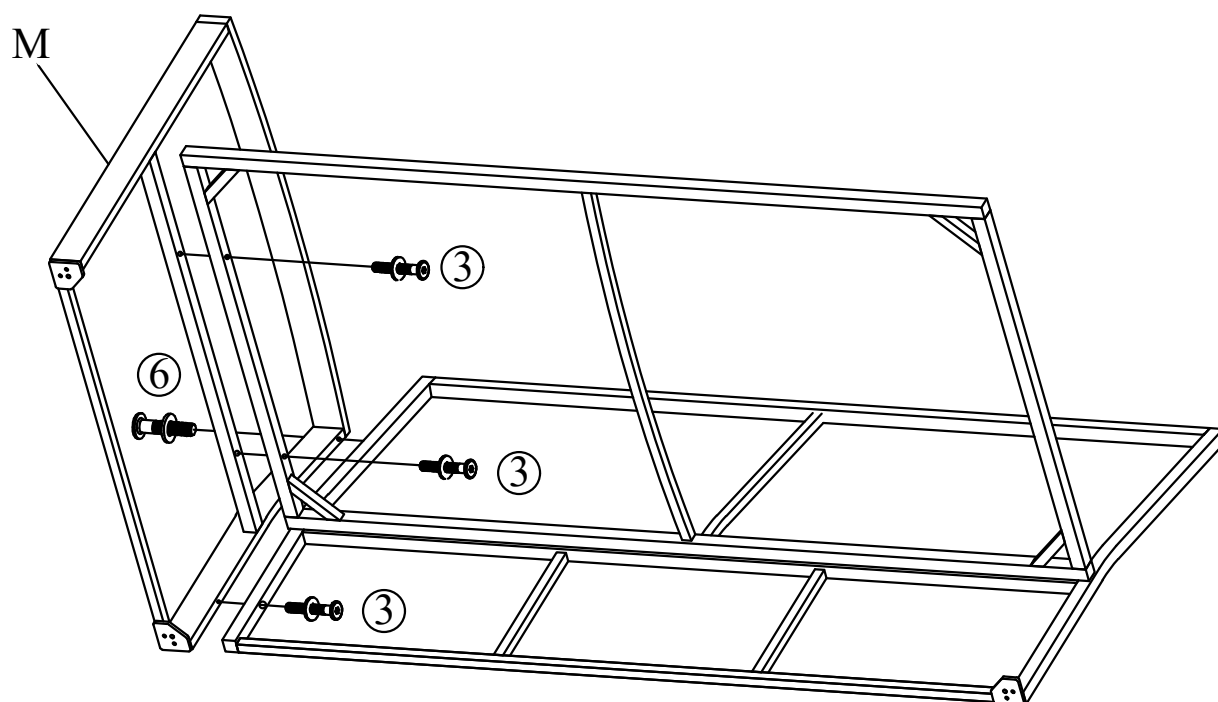



### STEP 9

Connect part from STEP 8 & Bench Right Side Frame (K) with Bolt (2)

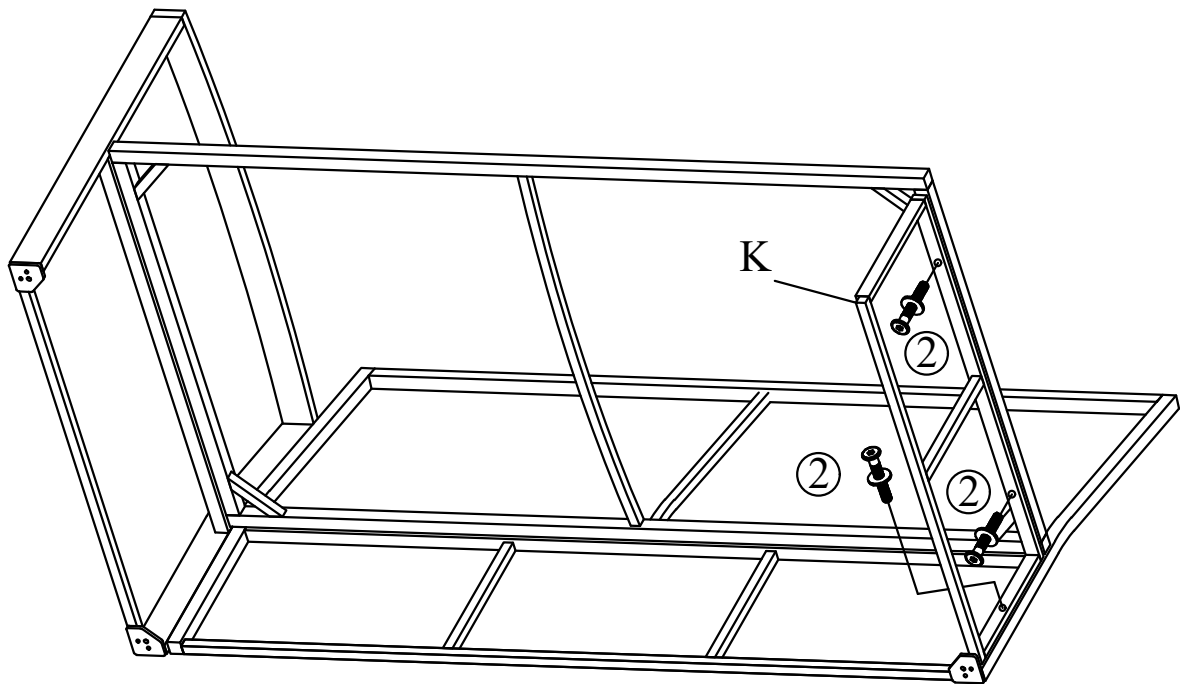

### STEP 10

Connect part from STEP 9 & Bench Right Front Frame (I) with Bolt (2)

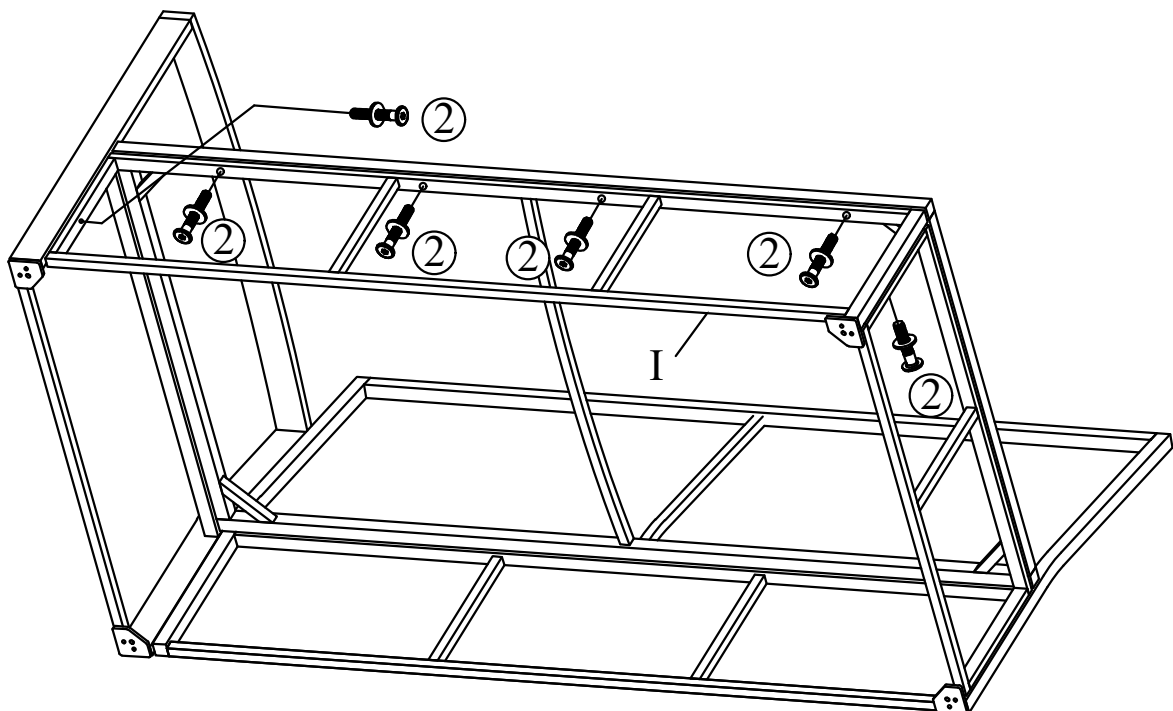

### STEP 11

Connect part from STEP 10 & Plastic Feet (7) with Bolt (5)

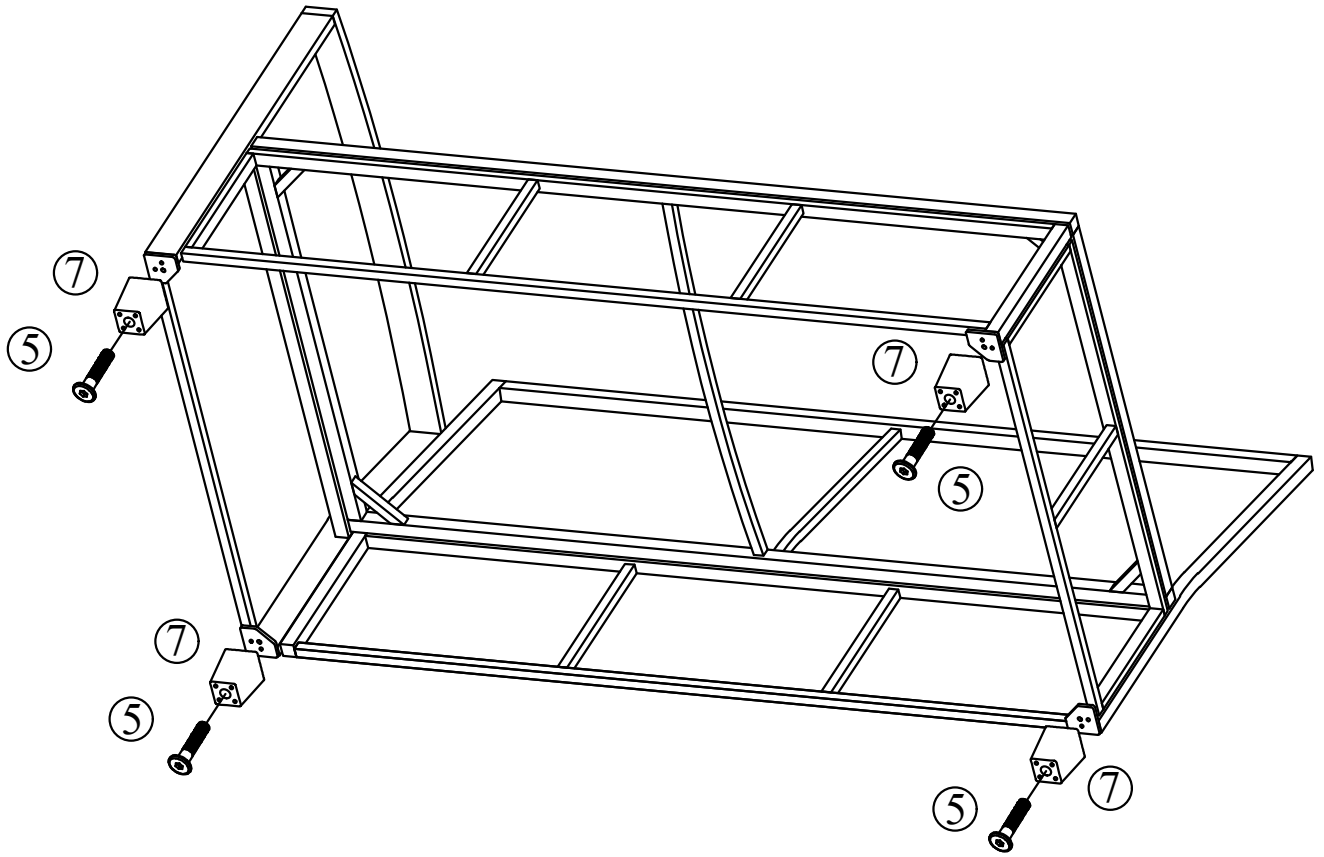

### STEP 12

Put on Bench Cushion (R), Back Long Cushion (S) to complete Bench

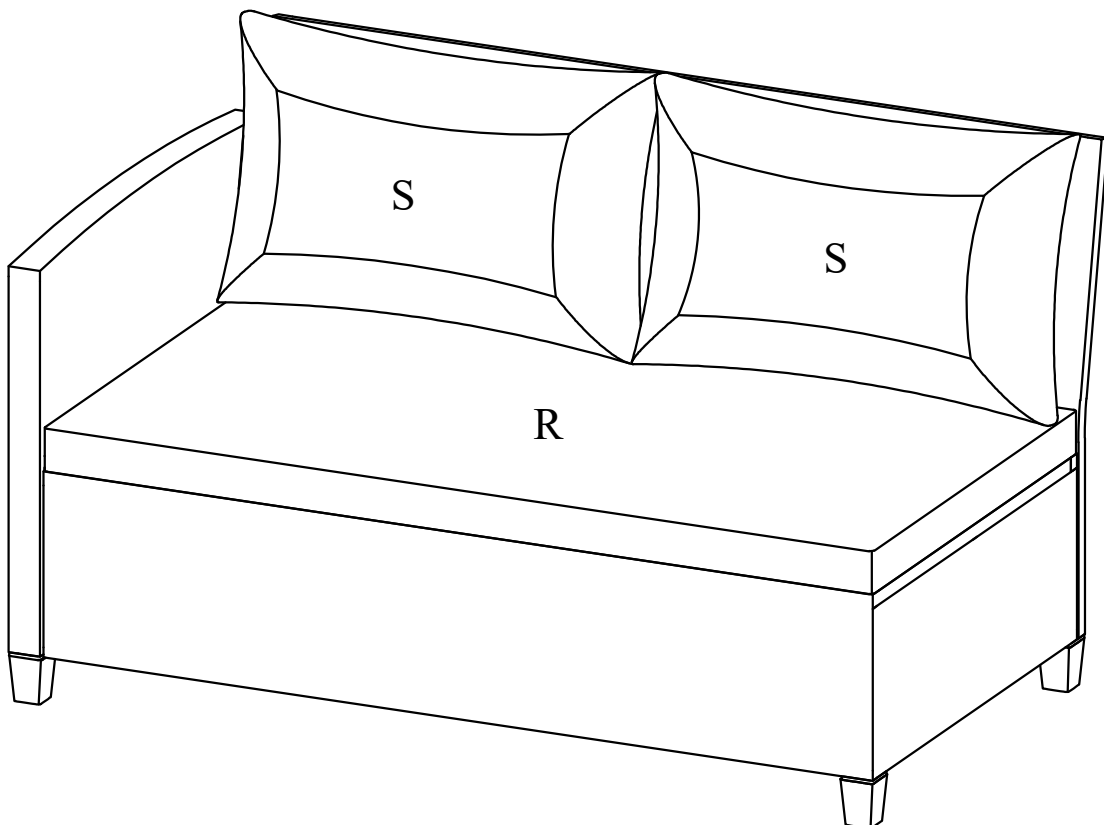

### STEP 13 (Corner Assembly)

Connect Corner Seat Frame (C) & Corner Short Back Frame (G) with Bolt (3)

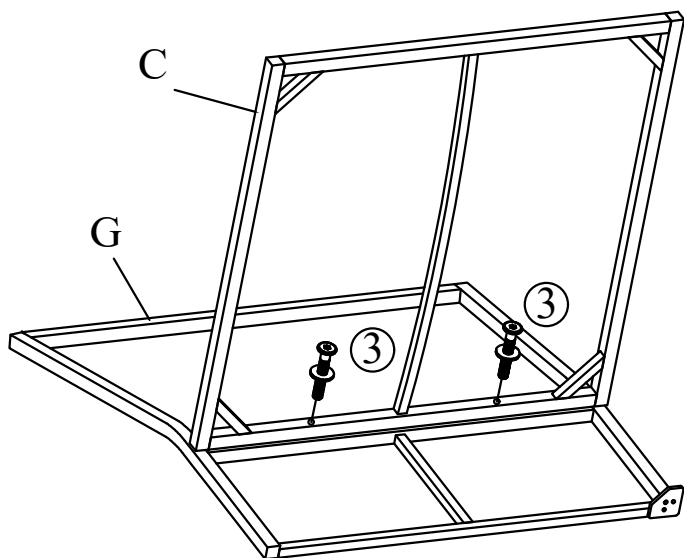

### STEP 14

Connect part from STEP 13 & Corner Long Back Frame (F) with Bolt (3), (4)

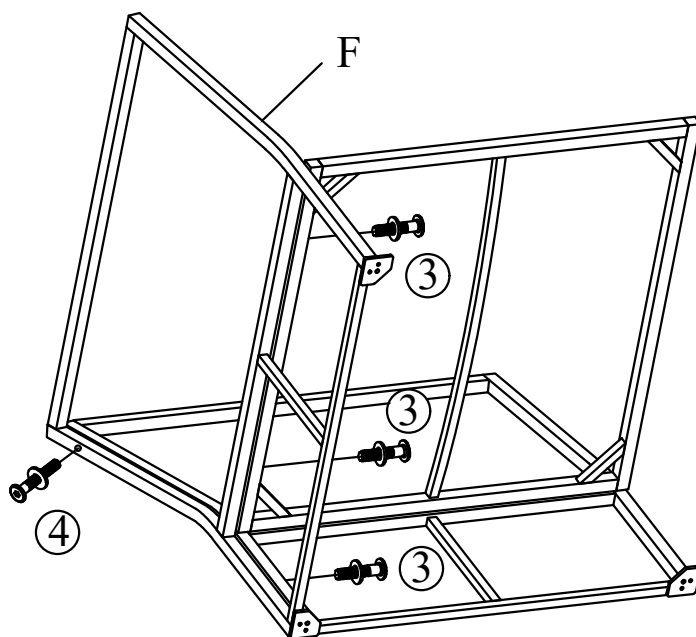

### STEP 15

Connect part from STEP 14 & Corner Side Frame (K) with Bolt (2)

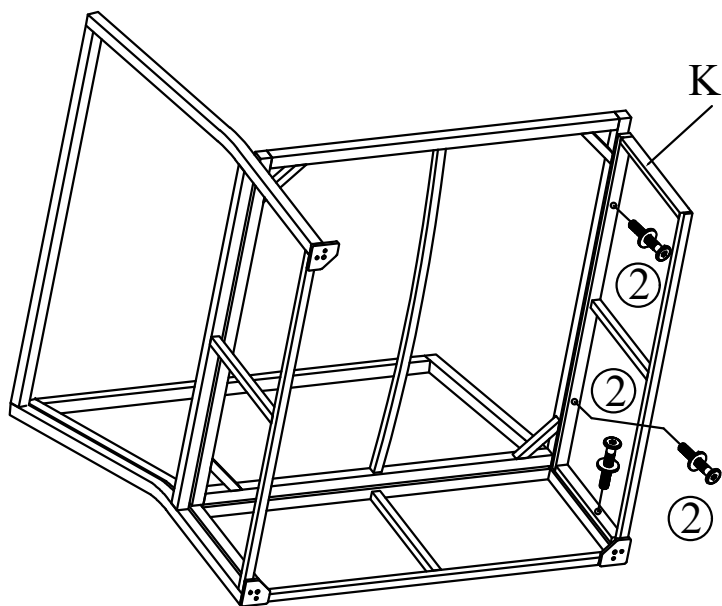

### STEP 16

Connect part from STEP 15 & Corner Front Frame (J) with Bolt (2)

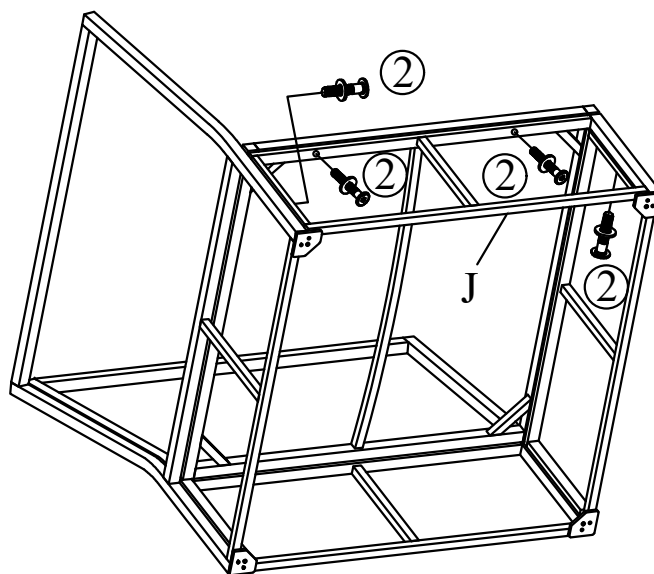

### STEP 17

Connect part from STEP 16 & Plastic Feet (7) with Bolt (5)

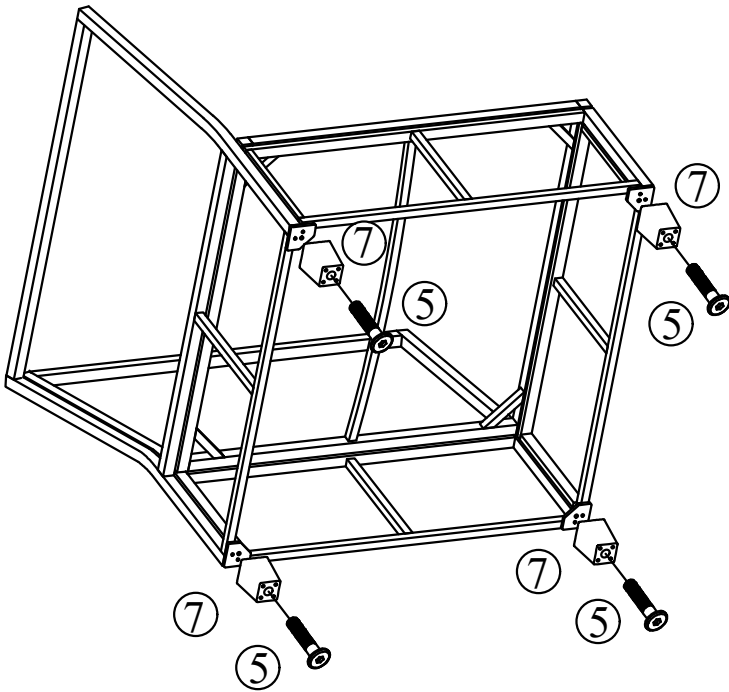

### STEP 18

Put on Corner Seat Cushion (Y), Back Long Cushion (S) & Back Short Cushion (V) to complete Corner

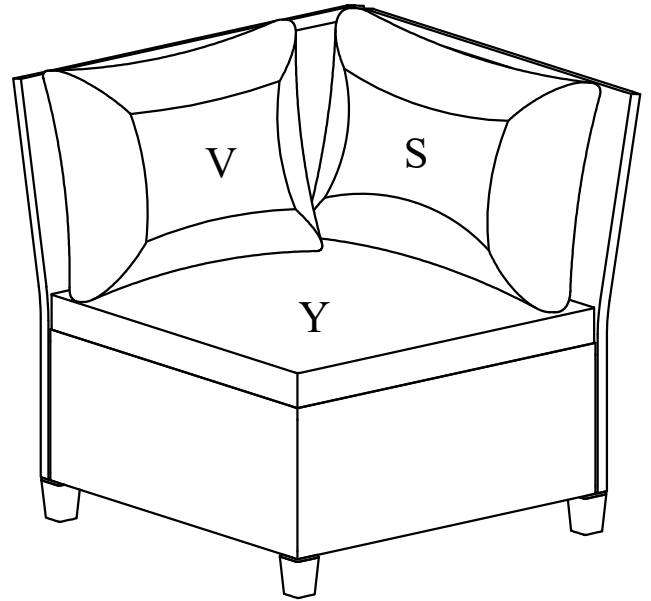

### STEP 19 (Stool Assembly)

Connect Stool Top Frame (Q) & Stool Side Frame (U) with Bolt (2)

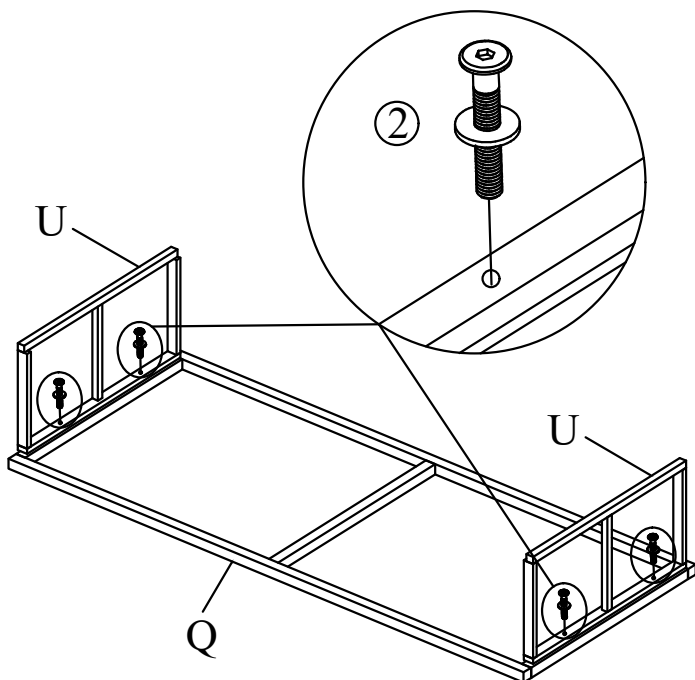

### STEP 20

Connect part from STEP 19 & Stool Front Frame (T) with Bolt (2)

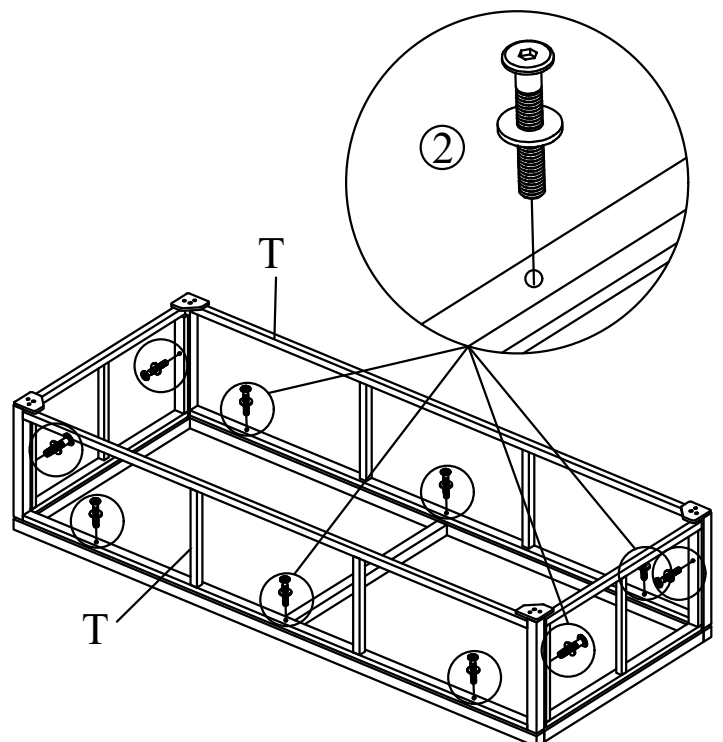

### STEP 21

Connect part from STEP 20 & Plastic Feet (7) with Bolt (5)

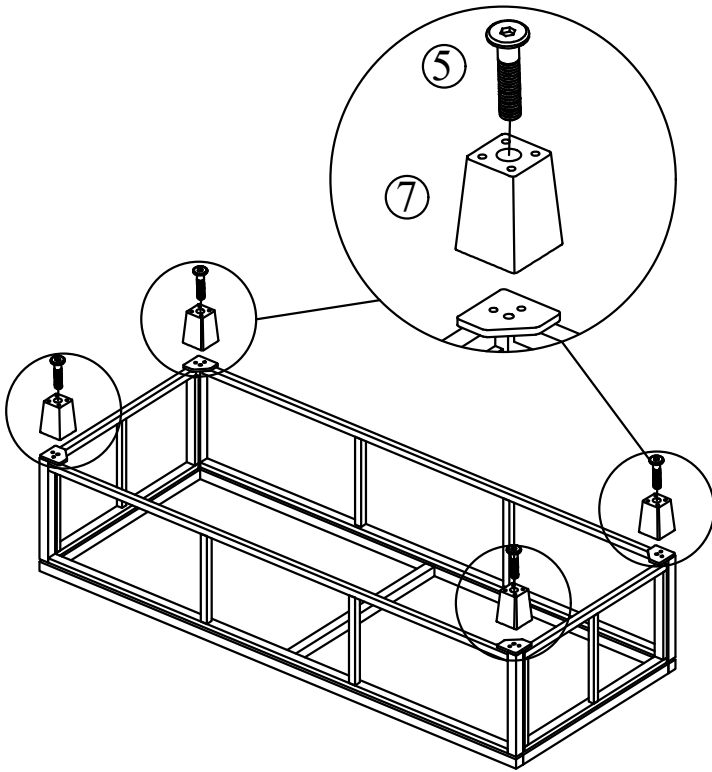

### STEP 22

Put on Stool Seat Cushion (X) to complete Stool

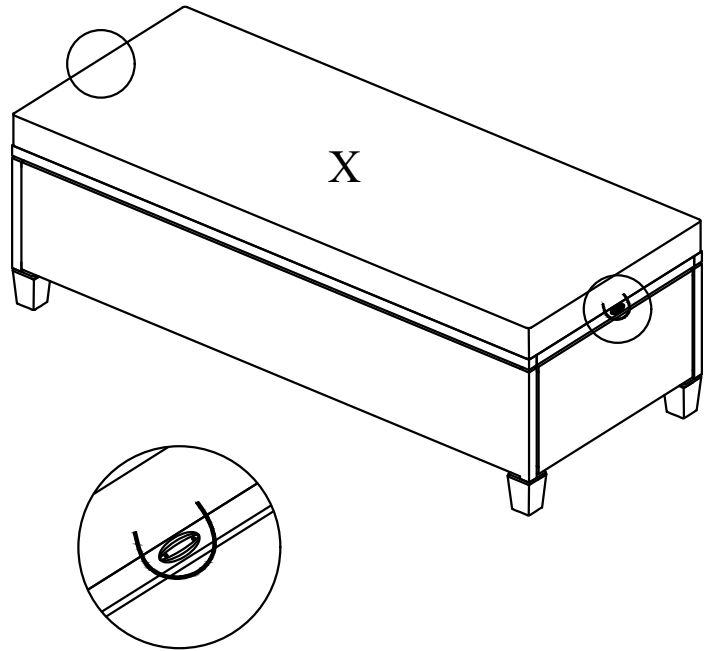

### STEP 23 (Table Assembly)

Connect Table Top Frame (N) & Table Leg Frame (O) with Bolt (1)

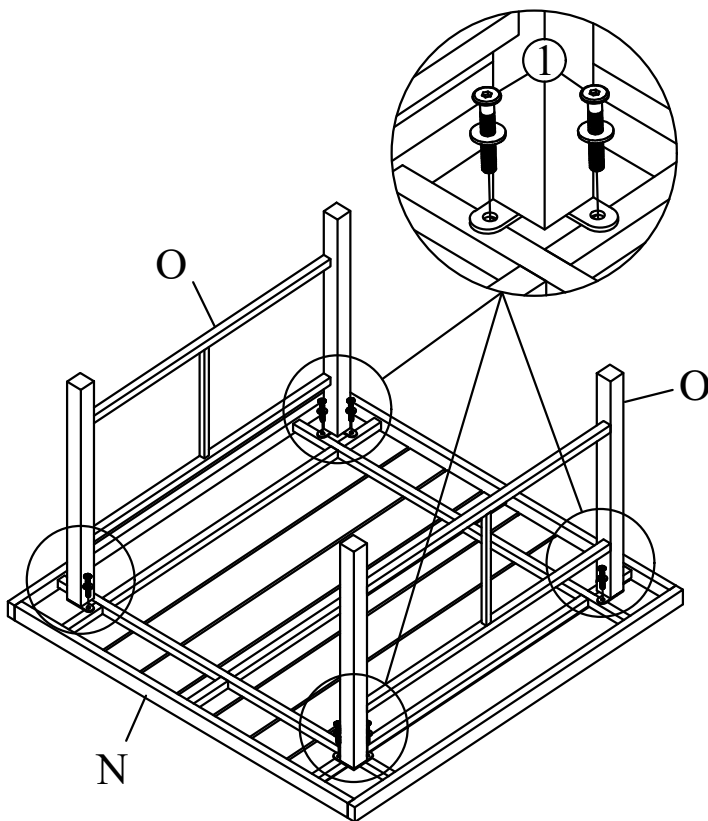

### STEP 24

Connect part from STEP 23 & Table Side Frame (P) with Bolt (3)

