

# ASSEMBLY INSTRUCTIONS

SKU: WF194171AAD

## IMPORTANT NOTE:





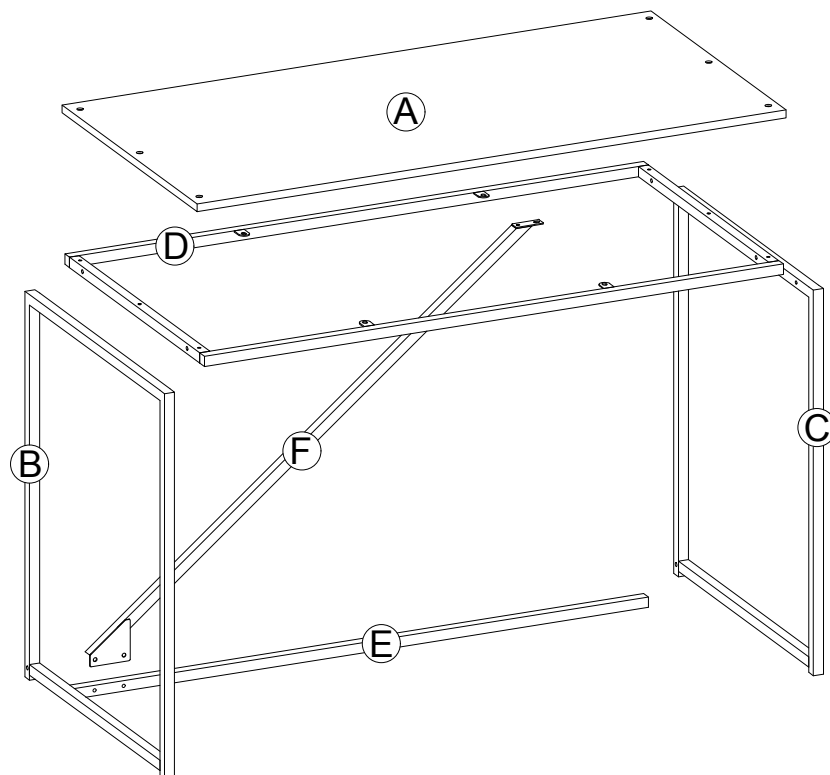
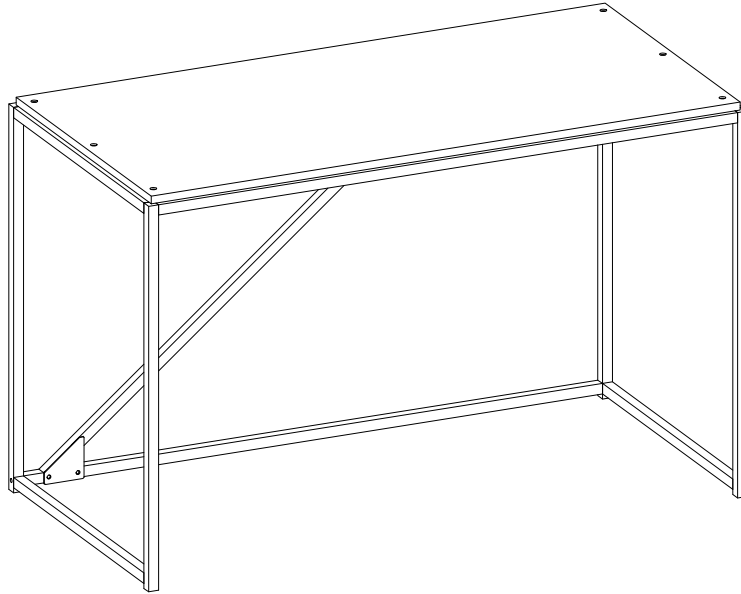

\*\*PLACE ALL PARTS ON A CLEAN AND SMOOTH SURFACE SUCH AS A RUG OR CARPET TO AVOID THE PARTS FROM BEING SCRATCHED.

\*\*BEFORE YOU BEGIN, KINDLY FOLLOW THE ASSEMBLY INSTRUCTIONS STEP BY STEP.





\*\*DO NOT TIGHTEN ALL SCREWS AND BOLTS UNTIL THE CHAIR IS FULLY SET-UP.



## Part List

	
A×1pc	B×1pc
	
C×1pc	D×1pc
	
E×1pc	F×1pc

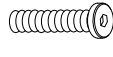
## Hardware List

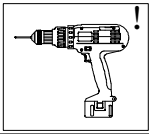

 M6×12mm ①×7pcs	 M6×30mm ②×10pcs
 M6×40mm ③×2pcs	 M4 ⑤×1pc

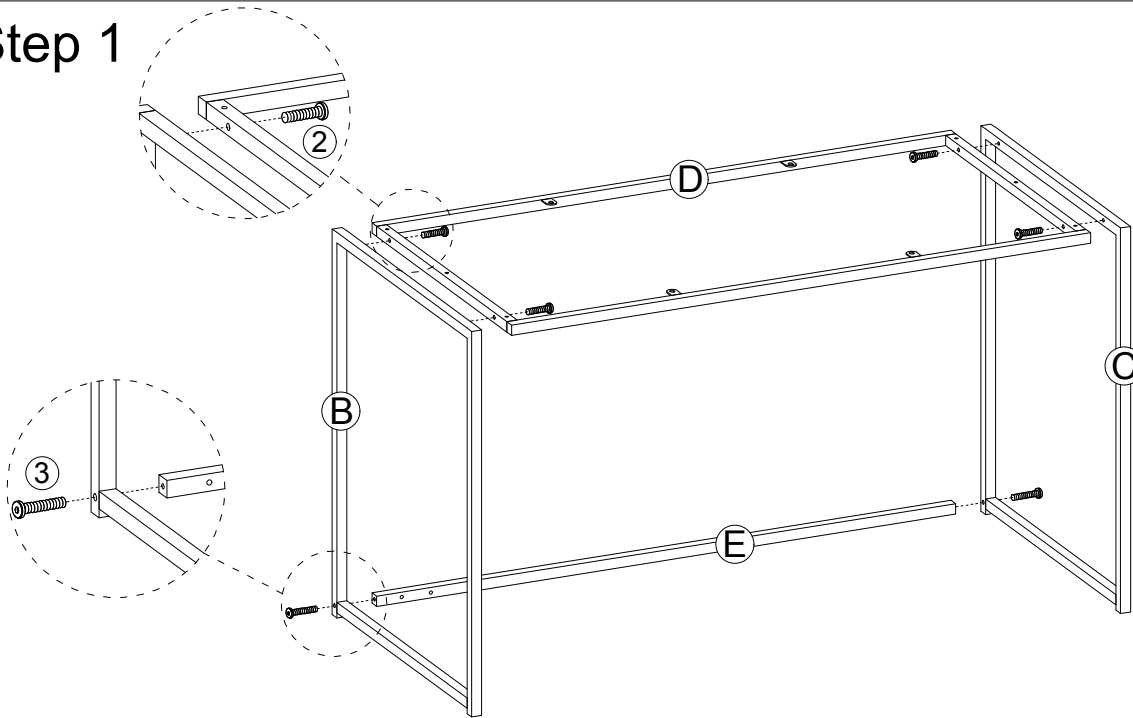

PLEASE BE CAREFUL DO NOT DAMAGE THE HOLE POSITION WHEN YOU USE POWER TOOLS !

## Step 1



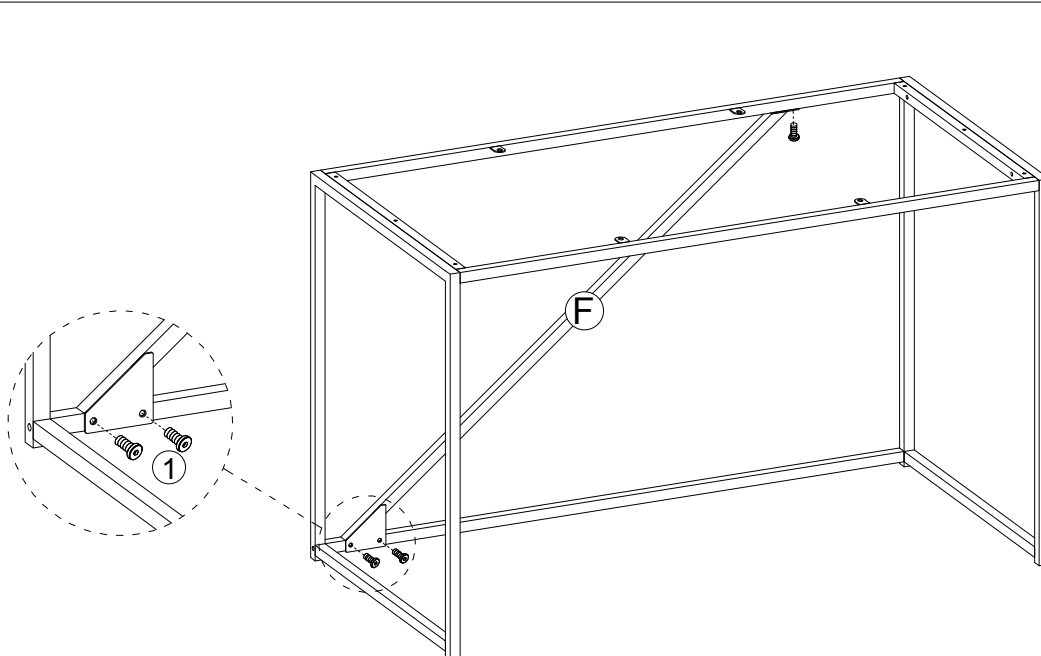

 M6×30mm ②×4PCS	 M6×40mm ③×2PCS
--	--



 M6×12mm ①×3PCS
--

# Step 3

 M6×12mm	 M6×30mm
①×4PCS	②×6PCS

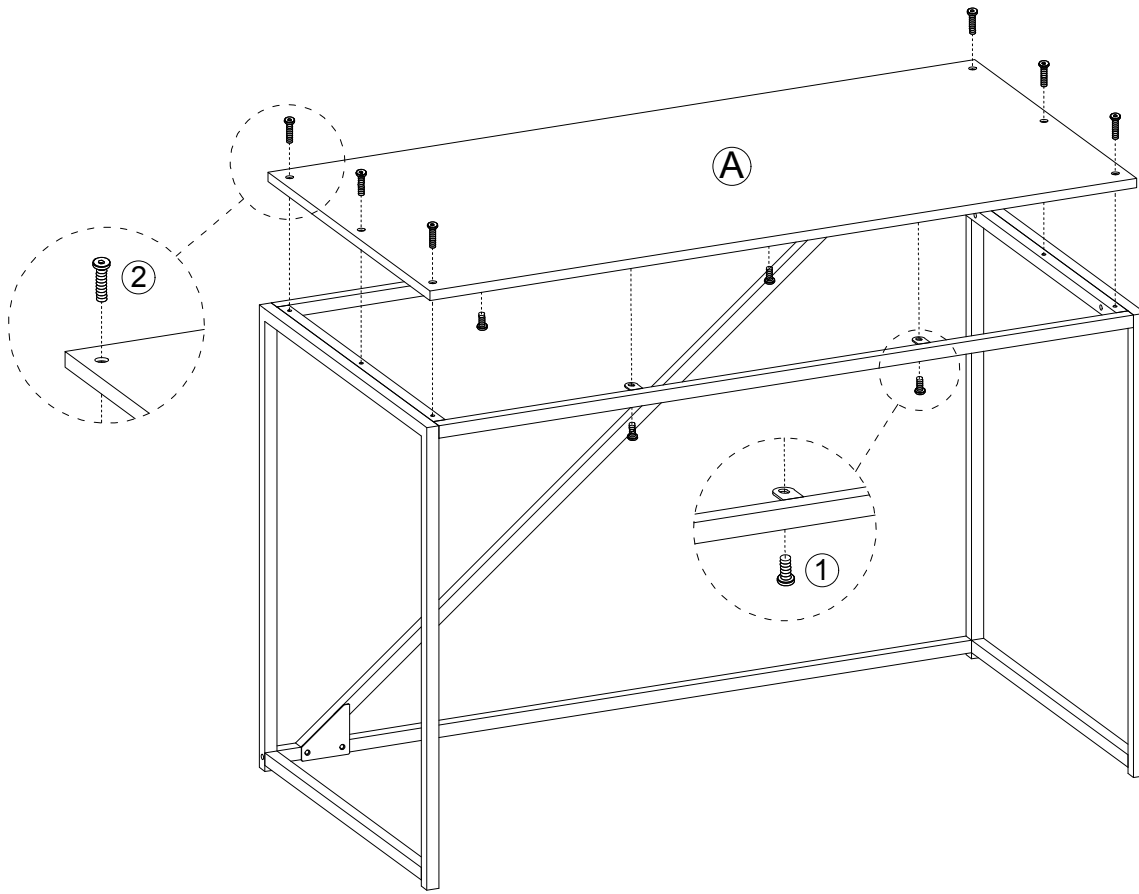

# Step 5

