

Instruction Manual

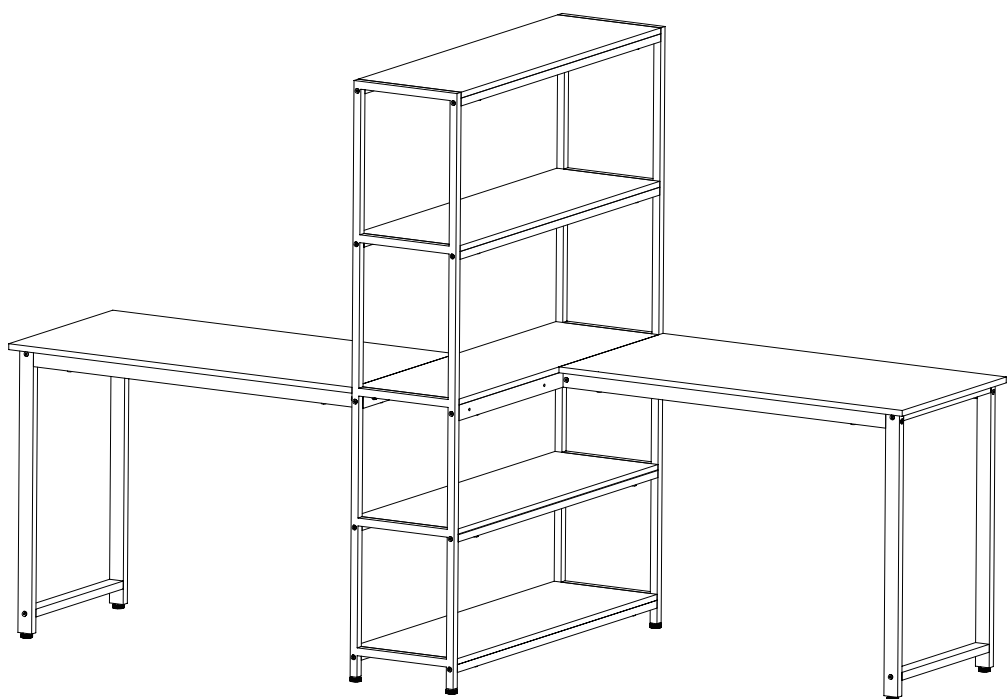

PARTS LIST

A x 2

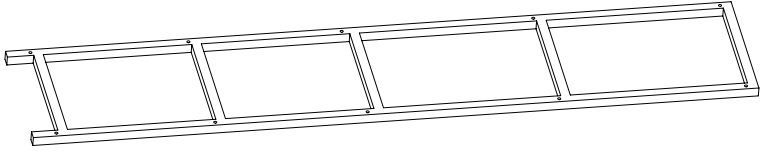

B x 8



C x 2



D x 2

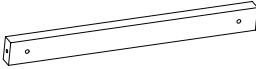

E x 4

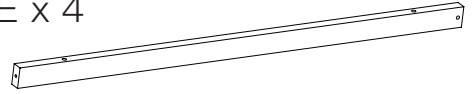

F x 4



G x 4

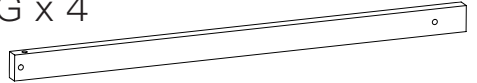

H x 5

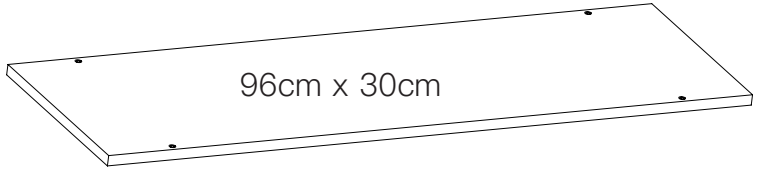

I x 2

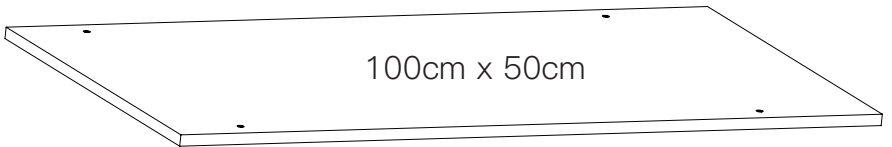

J x 8



K (M6x30) x 16

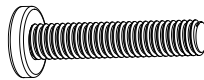

L (M6x35) x 32

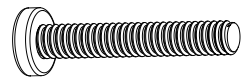

M (M6x50) x 16

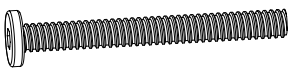

N (M6x55) x 4

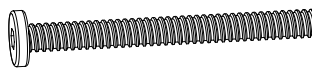

O x 4

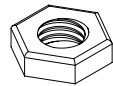

P

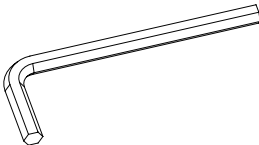

Q

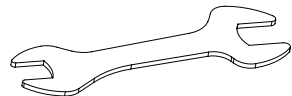

ASSEMBLY OVERVIEW

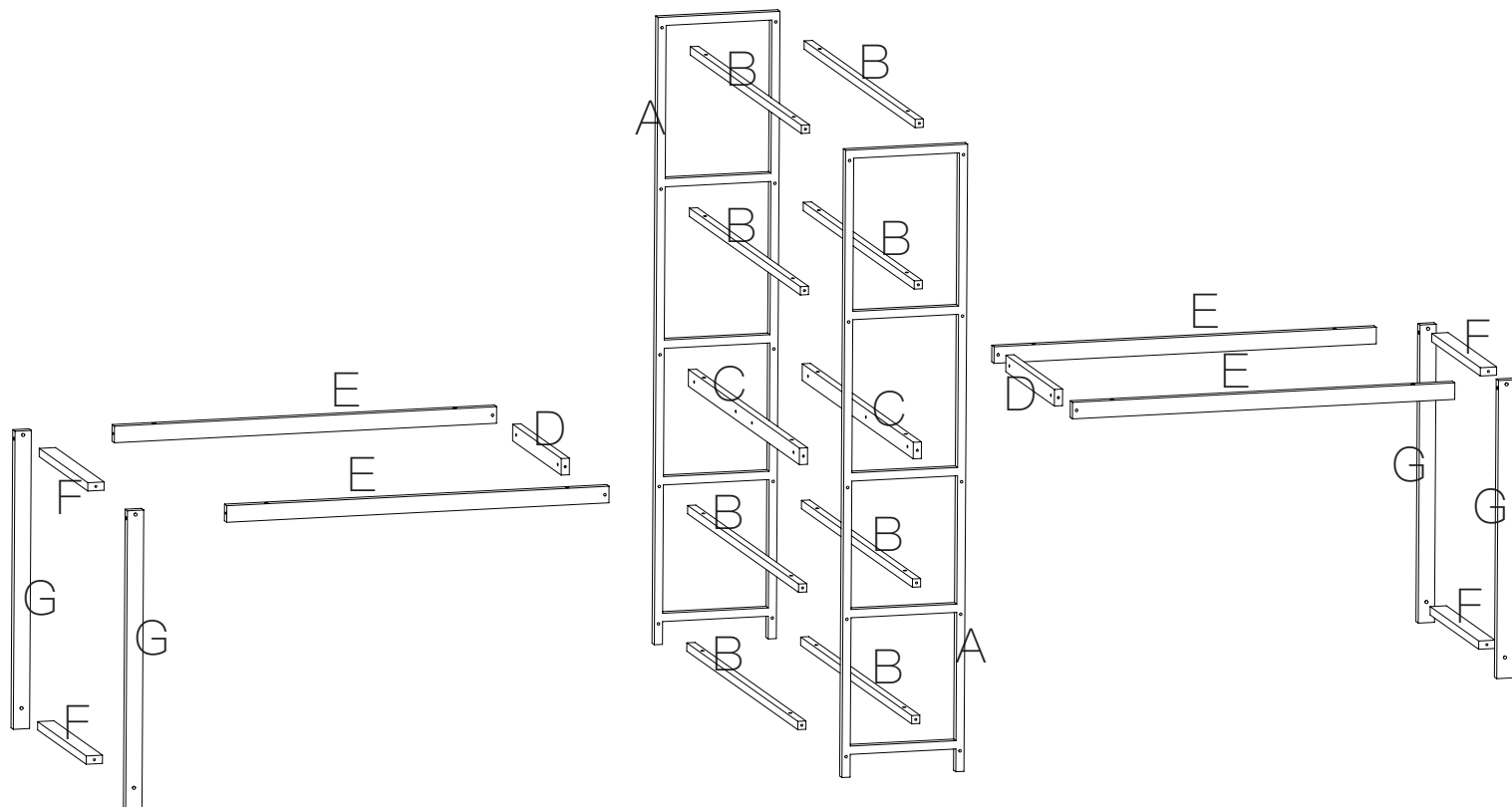

Step 1

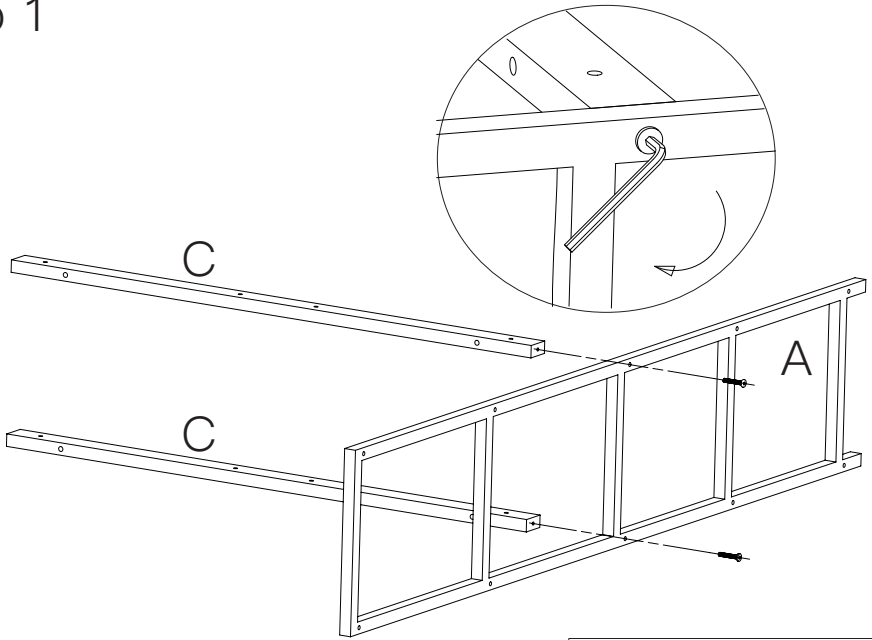

Do not over-tighten the bolts/screws



L x 2

Step 2

Pay attention to the position and direction of components , especially screw holes

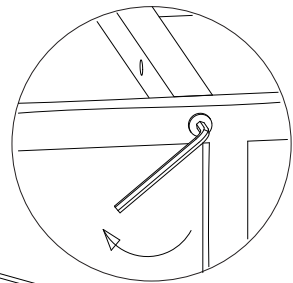

B x 8

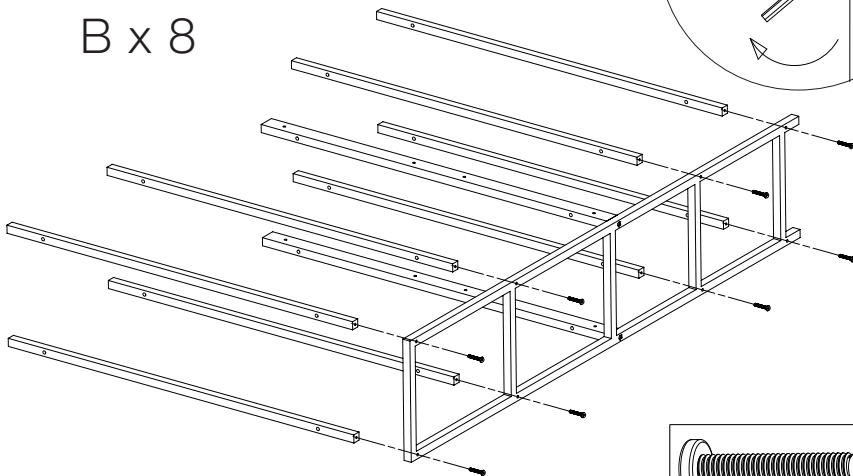

L x 8

Step 3

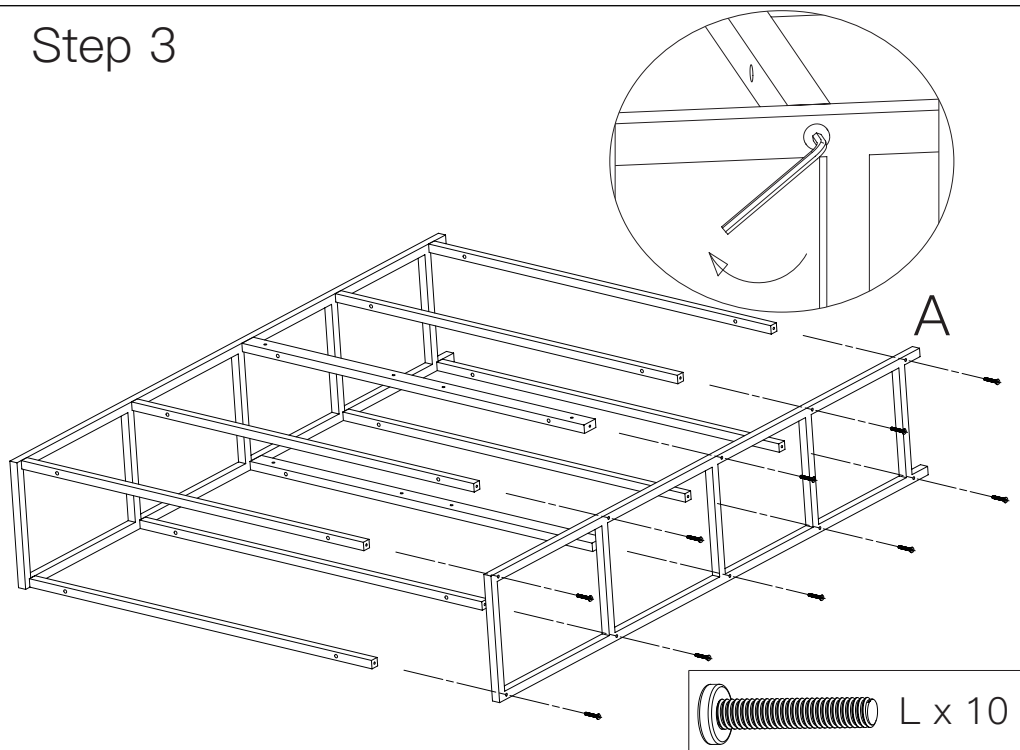

Step 4

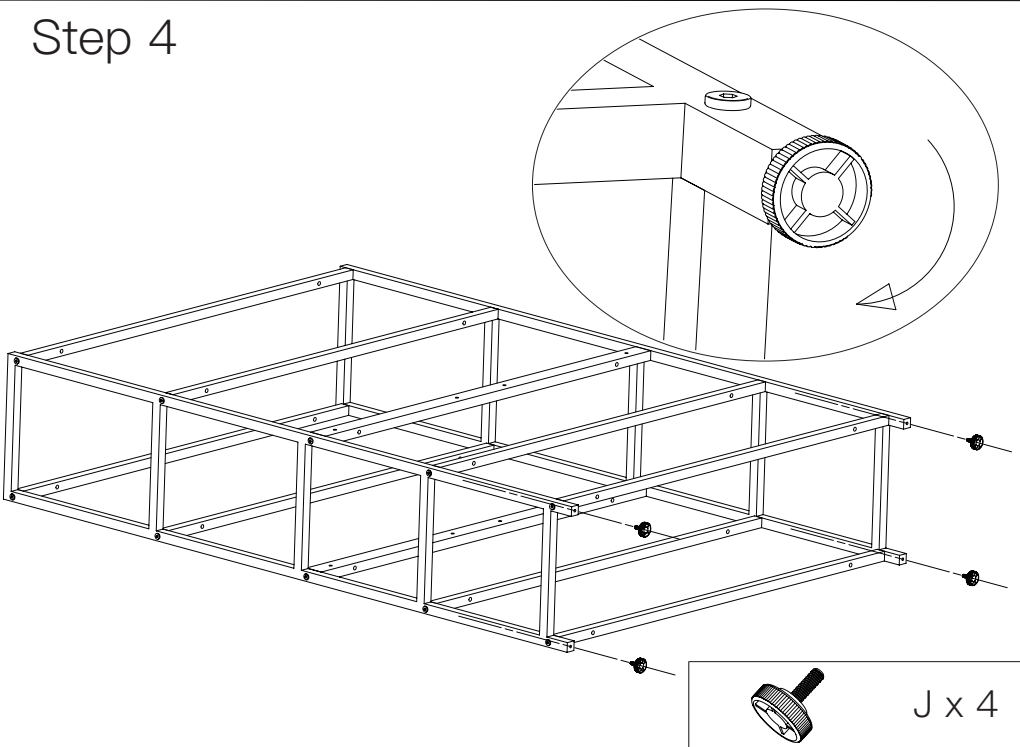

Step 5

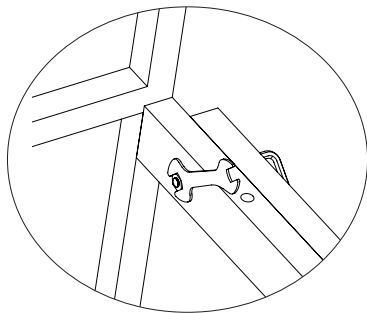
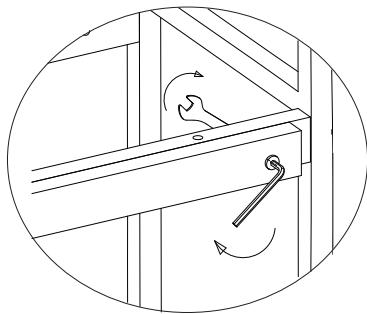
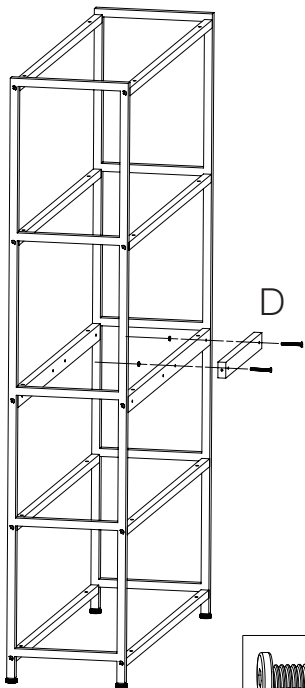

Step 6

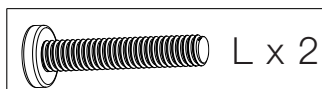
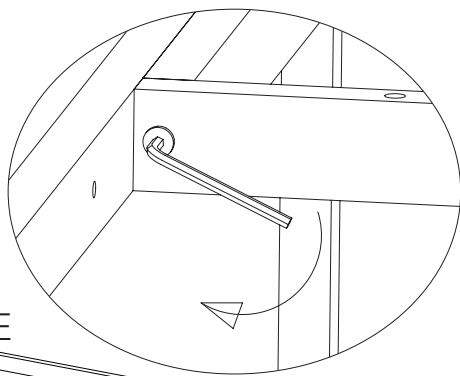
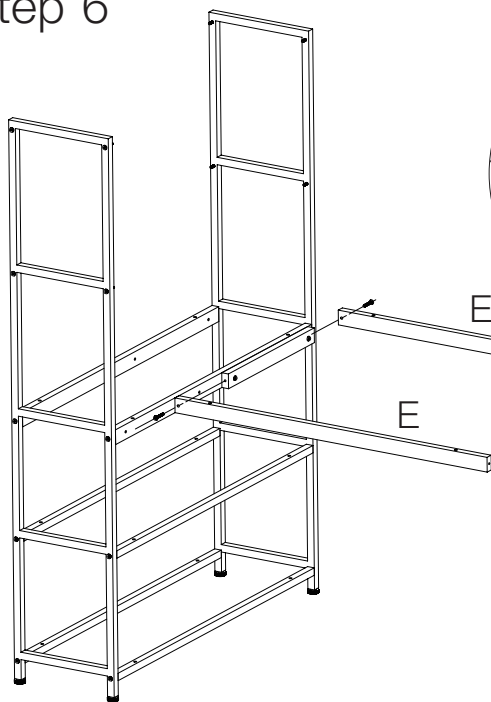

Step 7

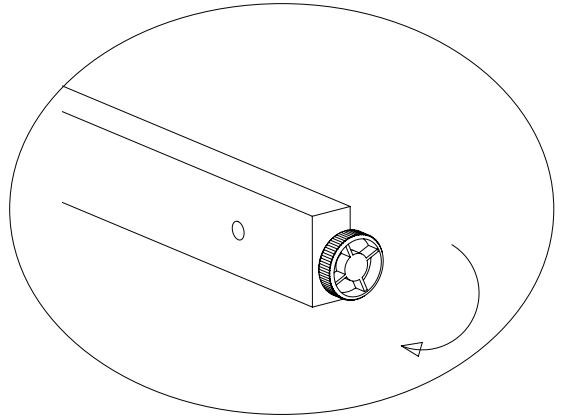
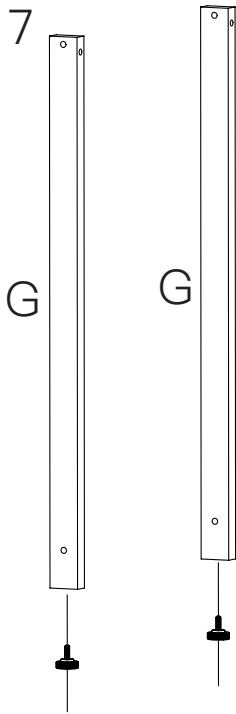

J x 2

Step 8

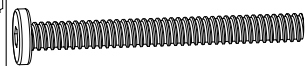
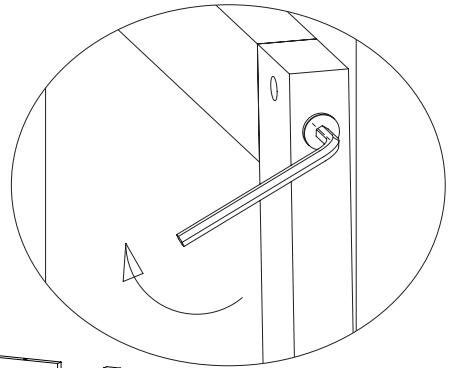
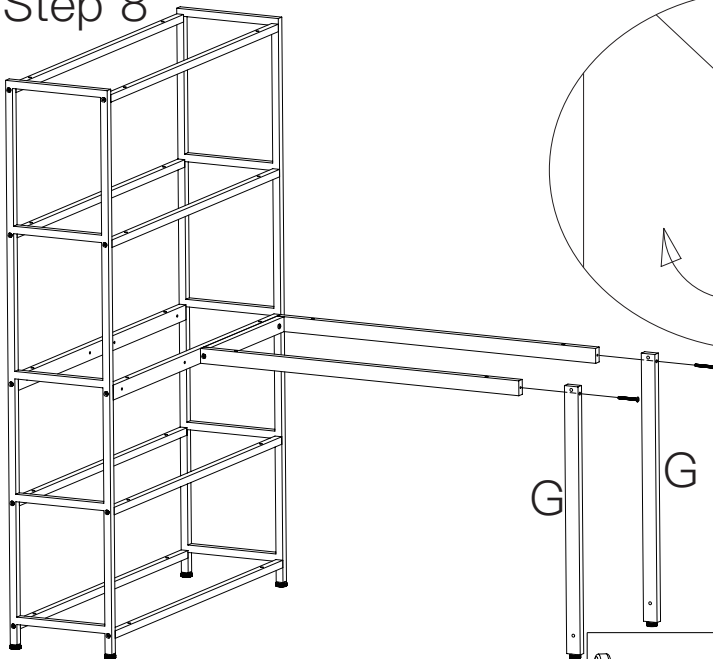

N x 2

Step 9

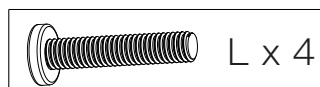
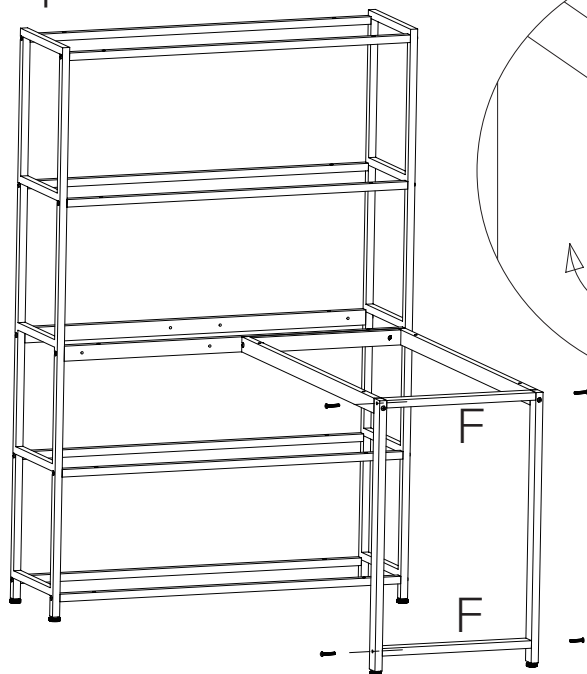

Step 10

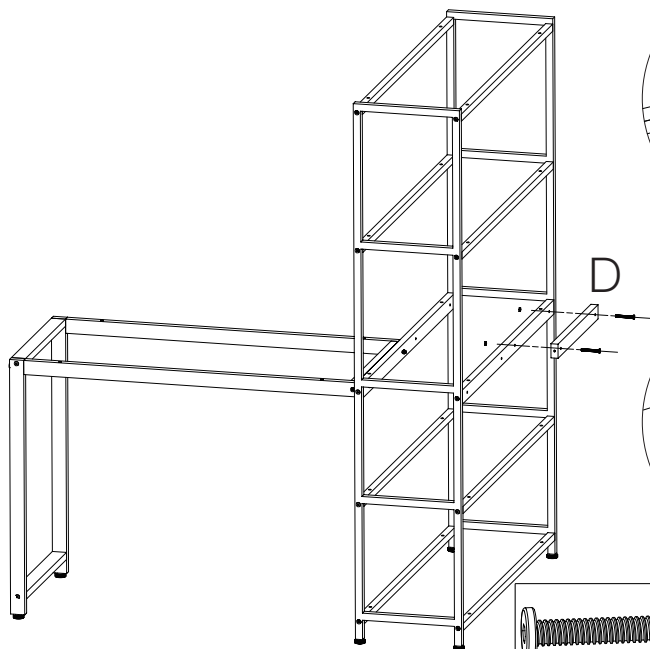

Step 11

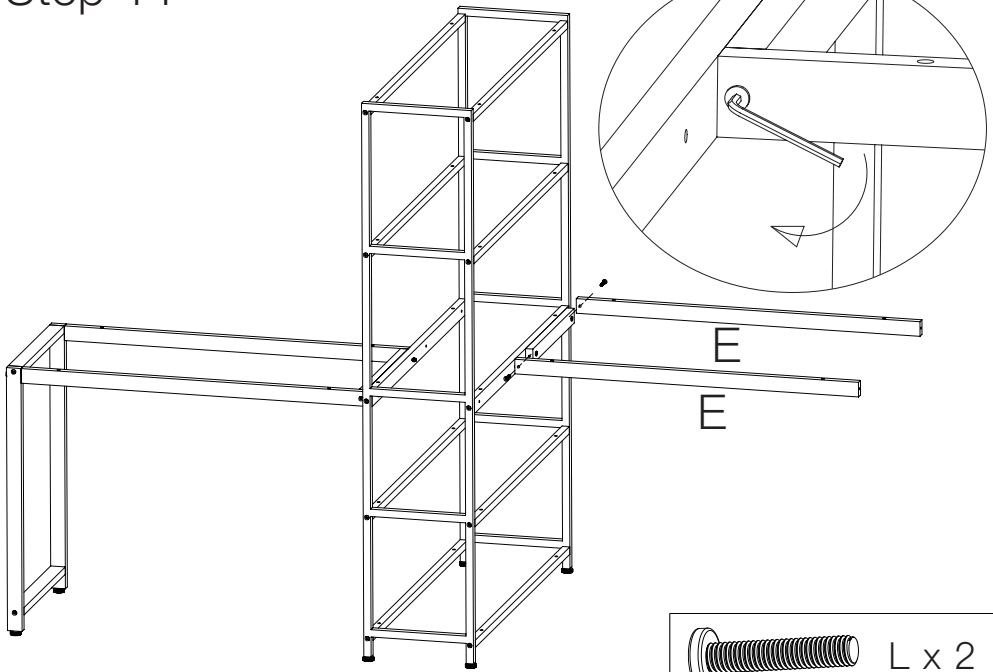

Step 12

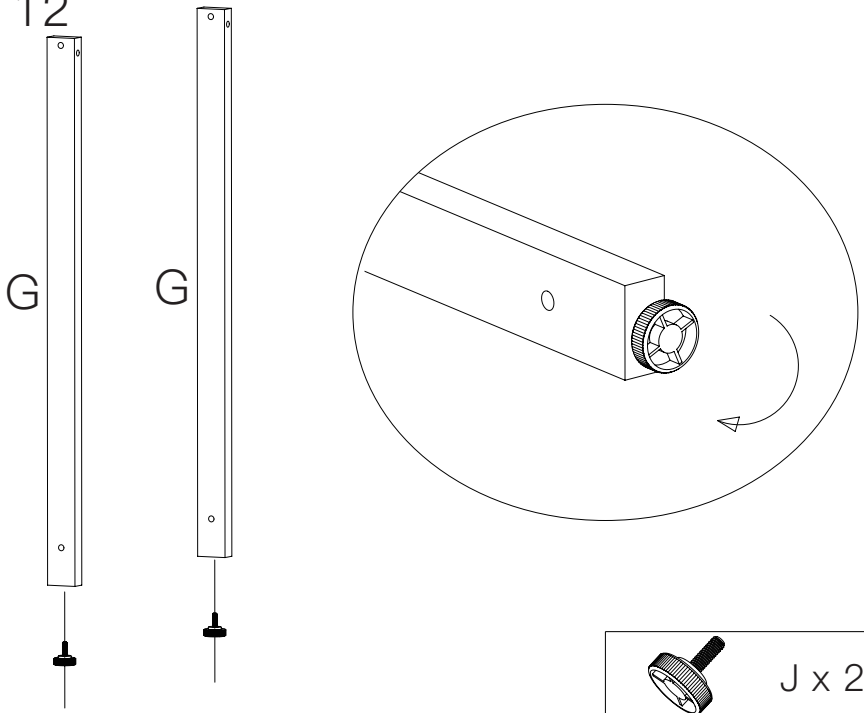

Step 13

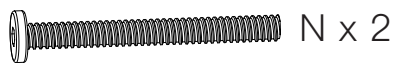
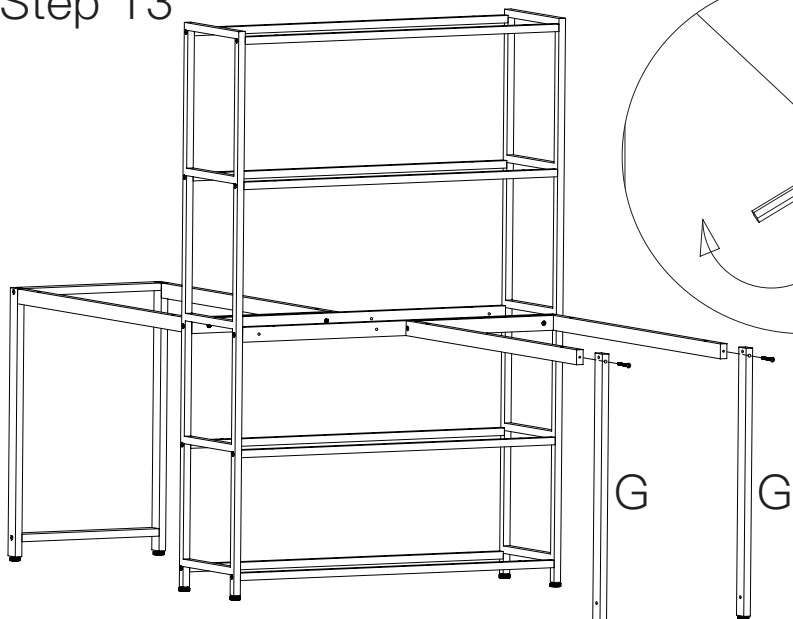

Step 14

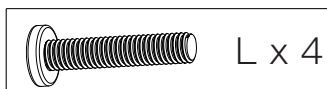
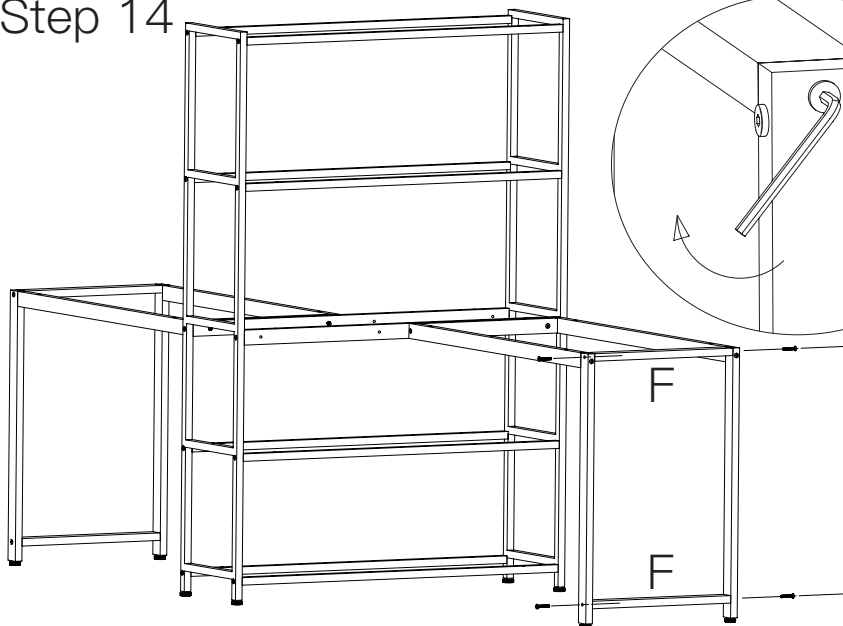

Step 15

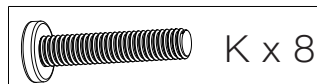
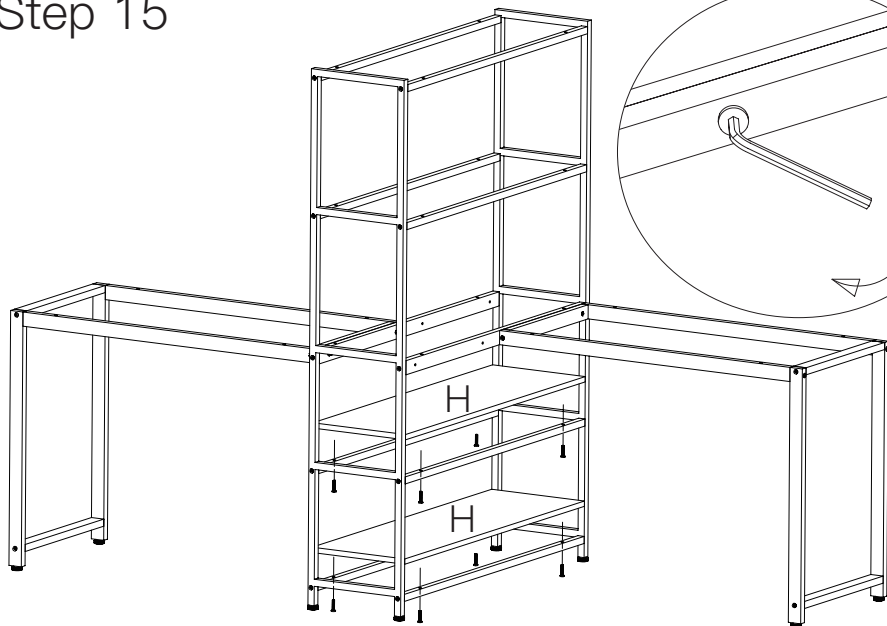

Step 16

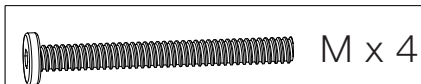
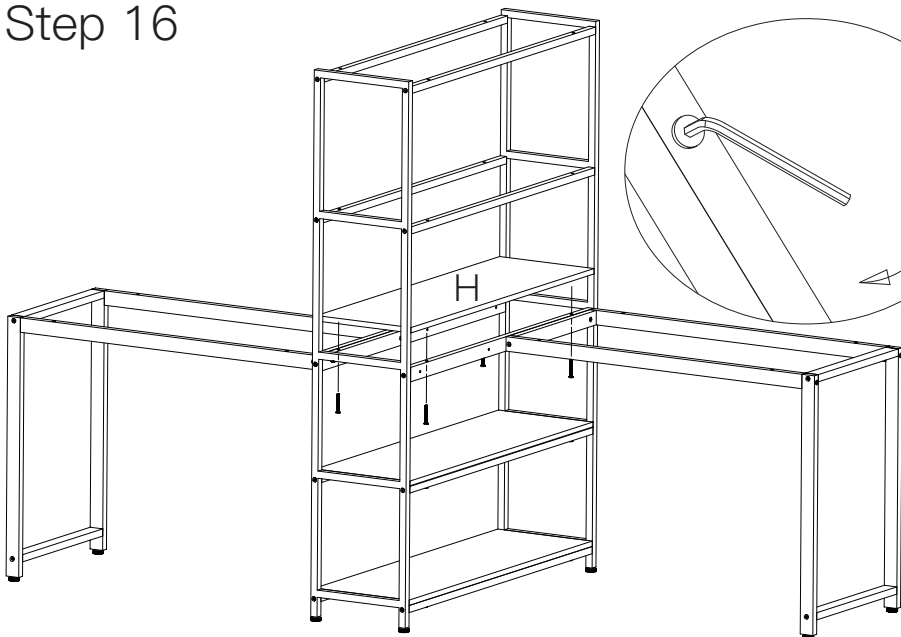

Step 17

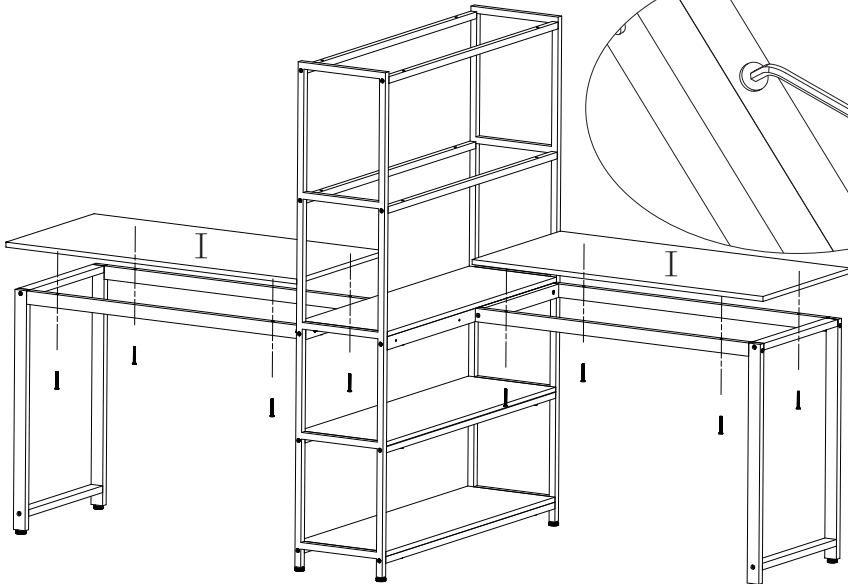

Step 18

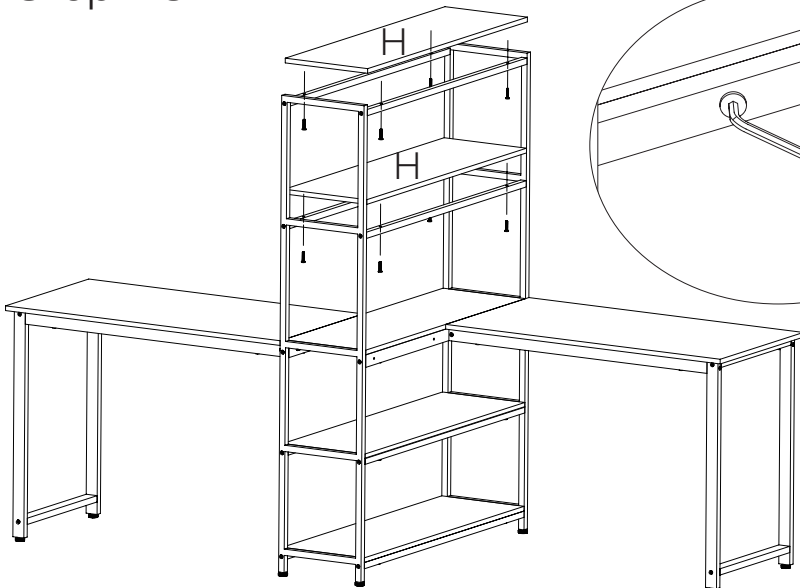

ASSEMBLE ACCOMPLISHED

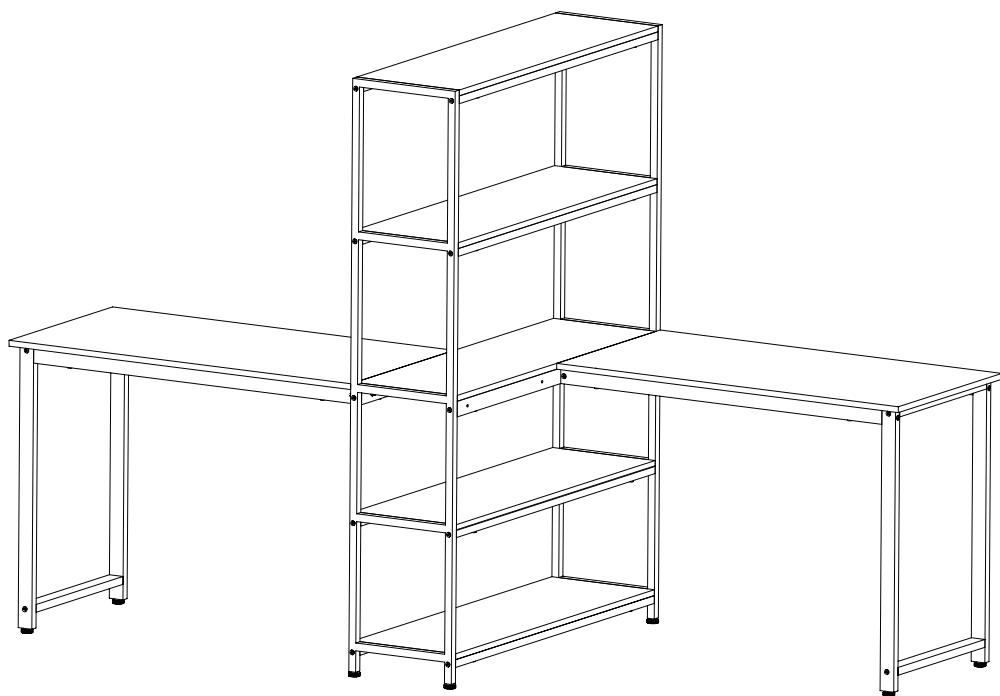

SAFETY AND MAINTENANCE

Every 6 months , check all screws to ensure they are tight .
Do Not use the product unless all screws are firmly secured .