

ASSEMBLY INSTRUCTIONS

ITEM NO.WF212560

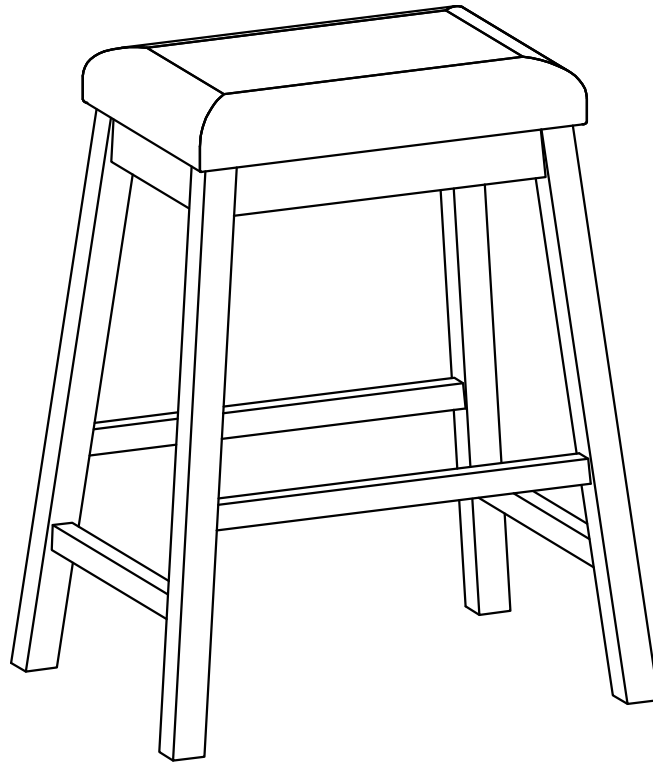



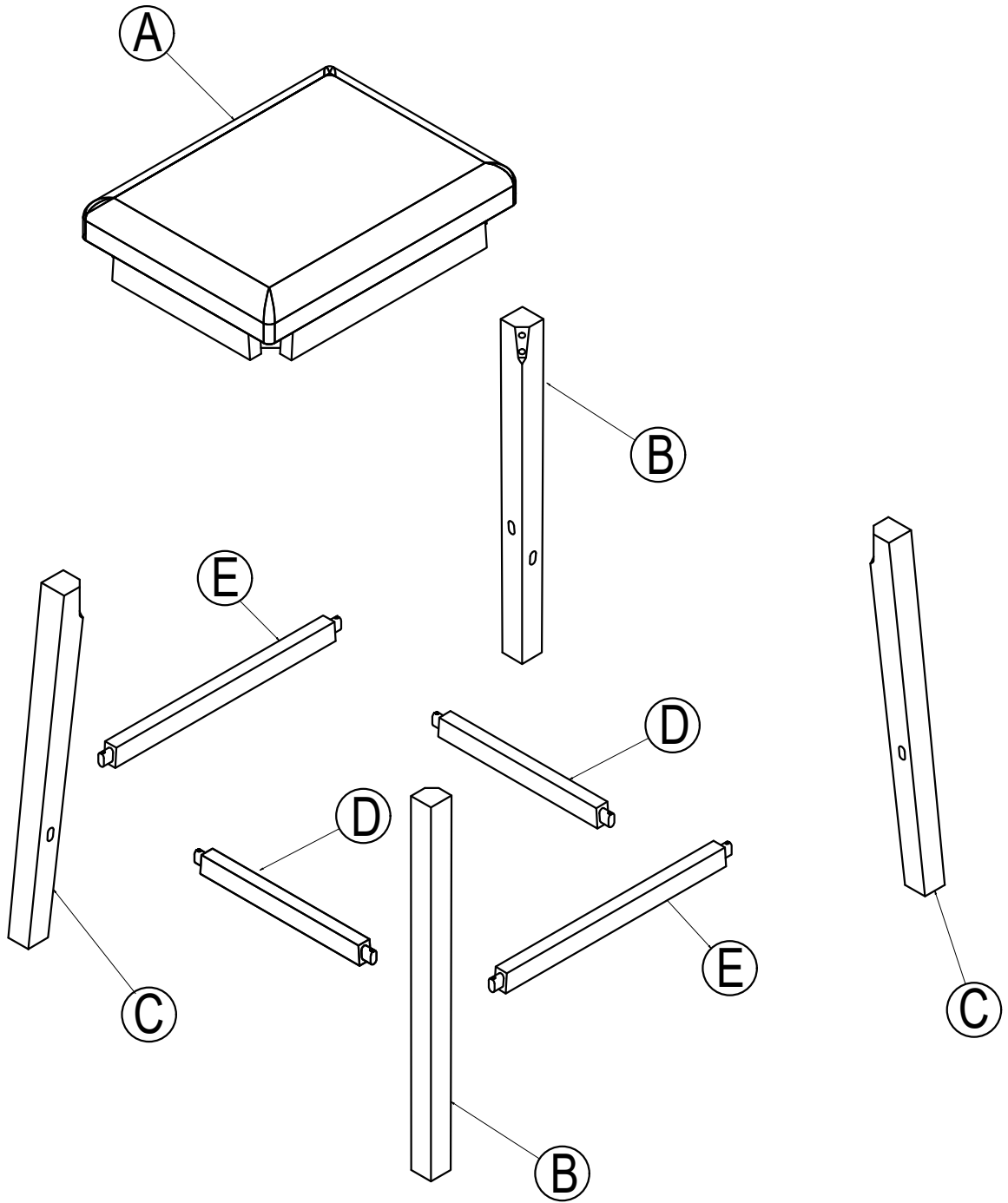

IMPORTANT NOTE :

- ① PLACE ALL PARTS ON A CLEAN AND SMOOTH SURFACE SUCH AS A RUG OR CARPET TO AVOID THE PARTS FROM BEING SCRATCHED.
- ② BEFORE YOU BEGIN,KINDLY FOLLOW THE ASSEMBLY INSTRUCTIONS STEP BY STEP.
- ③ DO NOT TIGHTEN ALL SCREWS AND BOLTS UNTIL THE CHAIR IS FULLY SET-UP.

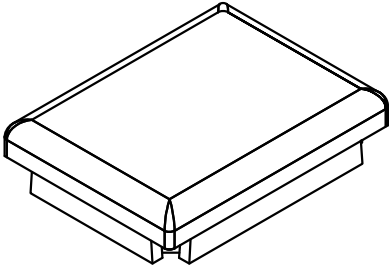
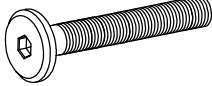
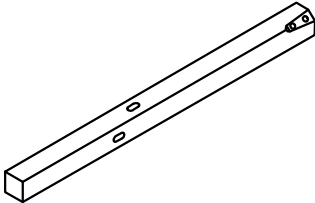

Part List

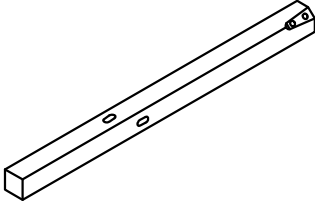
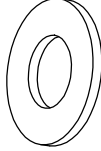
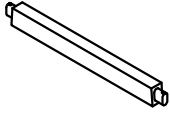
Hardware List

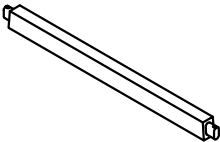
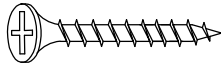
<p>(A)</p>  <p>CUSHION SEAT (4 pcs)</p>	<p>(1)</p>  <p>Ø 1/4" x 60 mm</p> <p>BOLT (32 pcs)</p>
<p>(B)</p>  <p>LEG LEFT (8 pcs)</p>	<p>(2)</p>  <p>Ø5/16" x 13 mm</p> <p>FLAT WASHER (32 pcs)</p>
<p>(C)</p>  <p>LEG RIGHT (8 pcs)</p>	<p>(3)</p>  <p>Ø5/16" x 19 mm</p> <p>LOCK WASHER (32 pcs)</p>
<p>(D)</p>  <p>SHORT STRETCHER (8 pcs)</p>	<p>(4)</p>  <p>4mm</p> <p>ALLEN KEY (1pc)</p>
<p>(E)</p>  <p>LONG STRETCHER (8 pcs)</p>	<p>(5)</p>  <p>Ø 4 x 38 mm</p> <p>WOOD SCREWS (32 pcs)</p>

STEP 1:

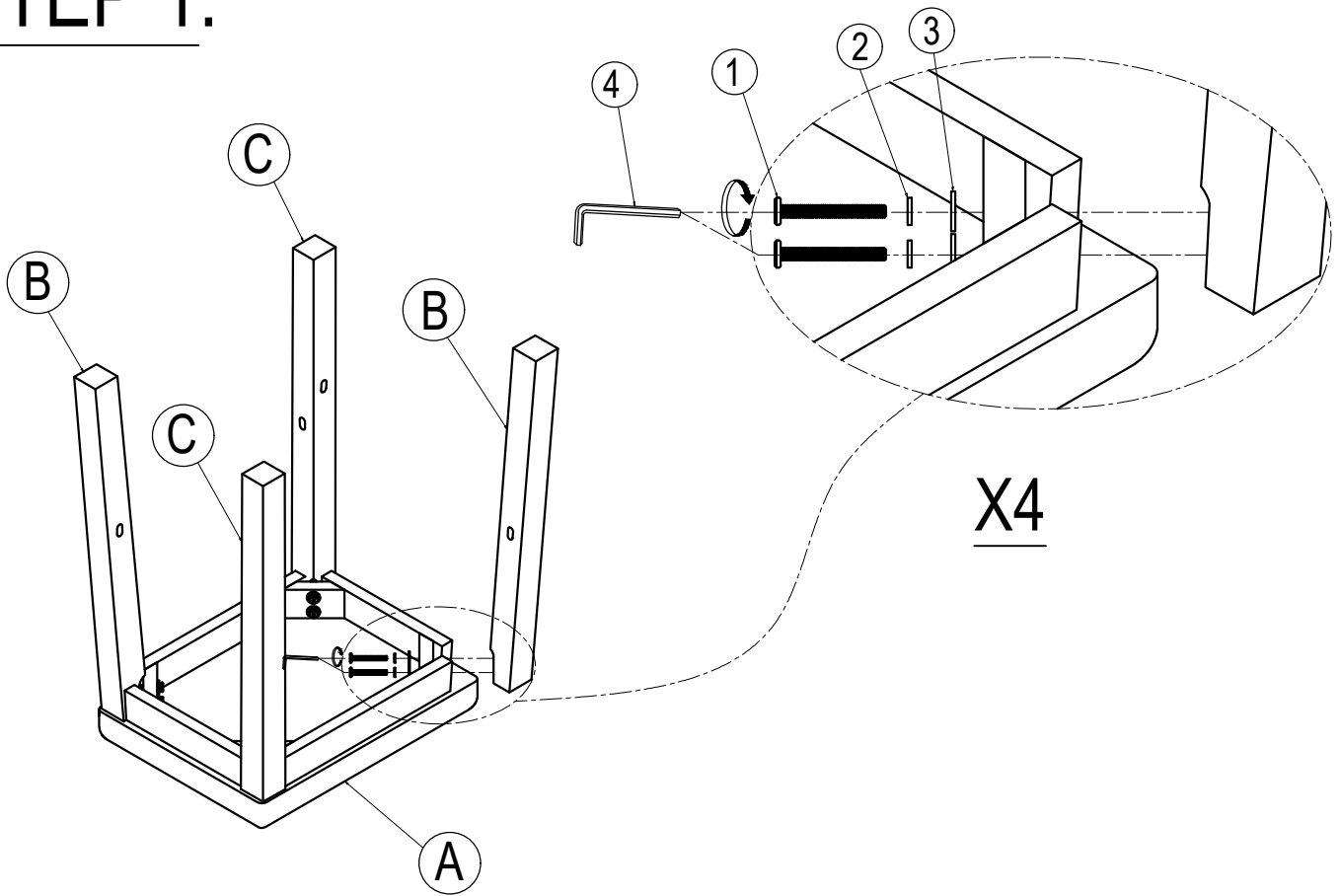

STEP 2:

